

CAP 403

Flying Displays and Special Events: Safety and Administrative Requirements and Guidance

Edition 17 | February 2020



Published by the Civil Aviation Authority
Civil Aviation Authority
Aviation House
Beehive Ring Road
Crawley
West Sussex
RH6 0YR

You can copy and use this text but please ensure you always use the most up to date version and use it in context so as not to be misleading and credit the CAA.

First published October 1973

Second edition July 1977
Reprinted February 1979
Reprinted August 1980
Third edition August 1982
Fourth edition January 1989
Fifth edition January 1990
Sixth edition March 1992
Seventh edition April 1995
Eight edition February 1998
Ninth edition 29 November 2002
Tenth edition 9 March 2007
Eleventh edition 1 April 2009
Twelfth edition 1 March 2010
Twelfth edition including amendment 2012/01, 29 June 2012
Thirteenth edition. February 2015 Re-written
Thirteenth edition 1 including amendment 2016, 1 March 2016
Thirteenth edition 2 including amendment 2016, 13 April 2016
Thirteenth edition 3 including amendment 2016, 24 May 2016
Thirteenth edition 4 including amendment 2016, 6 June 2016
Thirteenth edition 5 including amendment 2017, 20 February 2017
Fourteenth edition, May 2017
Fourteenth edition 1 including amendment 2017/01 May 2017
Fifteenth edition, March 2018
Sixteenth edition, January 2019
Seventeenth edition, February 2020

Enquiries regarding the content of this publication are to be addressed to:
General Aviation Unit, Safety and Airspace Regulation Group, Civil Aviation Authority,
Aviation House, Gatwick Airport South, West Sussex RH6 0YR

The latest version of this document is available at www.caa.co.uk/General-aviation/Displays

Contents

Contents	3
Revision History	9
Terminology and Definitions	13
General information	18
Introduction	18
Background.....	18
Safety Management.....	19
Reporting	20
Chapter 1	22
Flying Display legal requirements	22
Article 86.....	22
Private Flying Displays.....	23
Special Events	23
Dropping of articles (Article 89 of the ANO).....	24
Aircraft Races and Contests	24
Fly-ins	25
Military events, venues and military participation in civil Flying Displays	25
Foreign participation	25
Further reading	27
Chapter 2	28
Applying for a Flying Display or Special Event	28
Applying for permission.....	28
Identifying the permission required	29
The Map	30
Flying Displays and Special Events featuring only military aircraft	32
Charges	32
Flying Display charge bands	32
Exempt items	32
Assessment of charges.....	33
Feedback.....	33
Chapter 3	34
Application Timescales	34
Notification to the CAA	34
90 days prior to the event.....	34
60 days prior to the event.....	35
42 days prior to the event.....	36
30 days prior to the event.....	37
14 days prior to the event.....	37

Chapter 4	38
Personnel	38
Lines of responsibility.....	38
The Event Organiser (EO)	38
The Flying Display Director (FDD)	39
Airborne Flying Display Directors (AFDD).....	39
Flying Control Committee (FCC).....	40
Flight crew	40
 Chapter 5	 41
The Flying Display – planning and categorisation	41
Site assessment	41
Spectator areas and car parks	42
Drones and balloons	43
Commentator and public address systems.....	43
Secondary spectator considerations	44
Parking and ground manoeuvring of aircraft.....	44
Summary of separation distances for Flying Display planning.....	45
Hazardous materials	46
Display area.....	46
Separation Distances.....	50
Holding areas.....	51
Minimum heights.....	51
Categorisation of a flying display.....	52
Use and allocation of radio frequencies	53
Airspace considerations	53
Use of Transponder	54
Insurance.....	54
 Chapter 6	 56
The Flying Display – Management	56
Display Line	56
Display area restrictions.....	56
Over-flight of spectators	57
Setting of minimum heights.....	57
Military participation	58
Aircraft maximum speeds.....	59
Weather minima.....	59
Pyrotechnics used for ground special effects	61
Briefing	61
Display practises on the day of a Flying Display	62
Impromptu displays at Flying Displays	62
Arrivals and Departures from Flying Displays.....	63
Standard Warning and STOP calls	63
STOP Call and safety breach reporting and procedures	65
Standard display calls	67
Carriage of persons onboard display aircraft.....	67
Displays by Air Operator’s Certificate (AOC) operators.....	67
Pleasure flights	68
Pleasure flight escorts.....	69

Emergency Services	69
Inspection of Flying Displays and Special Events by the CAA.....	69
Chapter 7	71
Event Organiser (EO) – Guidance and information.....	71
The Event Organiser (EO)	71
Finding an FDD.....	71
Liaison with the Local Authority and Emergency Services.....	71
The Emergency Plan	72
Risk Assessment	74
Local Authorities	74
The Police.....	74
Fire and Rescue Services	75
Appointment of officials.....	76
Local landowners.....	76
Medical	77
Chapter 8	78
Flying Display Director (FDD) – Requirements and information.....	78
General.....	78
Display Area	79
Risk Assessment and emergency planning.....	79
Maritime Exclusion Zones	80
Danger areas	80
Deputy FDDs (DFDD).....	80
Document checks and insurance	81
Military participation	82
Foreign civilian participation	82
Tyro DA (TDA) participation	82
Parachute, paraglider, para-motors, hang-glider and foot-launched aircraft participation	84
Flying Control Committees (FCC)	85
Flying Display Director further considerations	86
Minimum heights and visibility.....	87
STOP Calls, Standard Warning Calls and safety breach reporting.....	88
Airborne Flying Display Directors (AFDD).....	88
Post display feedback	90
Reporting of occurrences and incidents	91
Action in the event of an aircraft accident.....	92
Summary of FDD responsibilities	92
Chapter 9	94
Air Traffic Services – requirements and information	94
General.....	94
Air Traffic Control Service	94
Flight Information Service	96
Air Ground Communication Service (AGCS).....	97
Flying Display operational communications.....	98
Air Traffic Service personnel	98
Frequency allocation.....	99

Radio licensing charges	99
Chapter 10	100
Ballooning as part of a Flying Display	100
Legal requirements	100
General exemption.....	100
Considerations.....	100
Chapter 11	102
Parachuting as part of a Flying Display	102
Legal requirements	102
Liaison and reconnaissance.....	103
The Parachute Landing Area (PLA)	103
The display	104
Chapter 12	105
Paragliders and Hang-gliders (unpowered) as part of a Flying Display.....	105
General.....	105
Pilot requirements.....	105
Liaison and reconnaissance.....	106
The Landing Area	106
The display (when the display forms part of a Flying Display)	107
Post-landing.....	107
Separation Distances.....	108
Down draughts, prop wash and jet blast	108
Chapter 13	109
Foot-launched aircraft as part of a Flying Display	109
General.....	109
Pilot access to the launch area	109
Separation distances	109
Down draughts, prop wash and jet blast	110
Maximum wind limitations	110
Chapter 14	111
Air racing as part of a Flying Display	111
General.....	111
Chapter 15	113
Banner towing as part of a Flying Display	113
General.....	113
DA requirements.....	113
Separation distances	113
Considerations.....	113

Chapter 16	115
Twilight and airborne pyrotechnic displays	115
General.....	115
Airborne displays using pyrotechnics	116
Pyrotechnic risk classification.....	117
Minimum Pyrotechnic Release Heights (MPRH)	117
Wind speed and direction of fallout and rate of fall	119
Anticipating a pre-ignition and / or failure in the air and on the ground	119
Safety information and special handling details.....	120
 Chapter 17	 121
Model aircraft and Unmanned Aircraft Systems (UAS) as part of a Flying Display	121
General.....	121
Model aircraft display limitations	122
Full size and model aircraft synchronised displays	123
 Appendix A	 124
Risk Assessment	124
Flying Display risk management	124
Why is risk management important?	124
The risk management process	124
Hazard / risk definition	127
Hazard identification	127
Risk Assessment	129
Risk Likelihood (L)	129
Risk Severity (S).....	130
Risk tolerability.....	131
Risk rating categories	132
Risk mitigation	133
Risk Recording	135
Monitoring and improvement.....	135
Flying Display Risk Assessment	135
Flying Display Risk Assessment in Flying Display applications	137
 Appendix B	 143
Written, verbal and telephone briefings	143
The display pilot's written brief	143
The verbal brief.....	147
Telephone briefing	149
Formation briefings and walk throughs.....	149
 Appendix C	 151
Flying Display Director Accreditation	151
Obtaining Flying Display Director accreditation	151
Flying Display Director accreditation course.....	152
Validity and currency.....	154

Upgrades	155
Mentoring / shadowing	156
Renewals	157
Lapsed and expired FDDs	157
Revocation	158
Appendix D	159
FAiR System	159

Revision History

Edition 12

March 2010

This revision incorporates changes to the Air Navigation Order (ANO) references to reflect the 2009 edition of the ANO.

Other minor editorial corrections, convenient to be included at this time, have also been included. All technical changes are marked by a marginal line.

Edition 12, Amendment 2012/01

June 2012

This amendment amends Chapter 6, paragraphs 3.1 and 4 to address two AAIB Safety Recommendations (2011-001 and 2011-002 in FACTOR 02/2011). Due to their urgent nature these changes have been made ahead of the major revision to this CAP.

Edition 13

February 2015

This revision is a complete rewrite of CAP 403. The CAP is now split into Part A and Part B covering Flying Displays and Special Events respectively.

Edition 13, Amendment 2016/01

March 2016

Amends to reflect change in display application requirements (Chapter 3 Part A, Chapter 4 Part A and Annex A – Risk Assessment) and introduction of fitness assessment for Flying Display Directors and Display Pilots (Chapter 1 Part A). All subsequent to CAA's review of Flying Display regulation conducted in 2015/6. Due to their urgent nature these changes have been made ahead of a major revision to this CAP in late 2016.

Edition 13, Amendment 2016/02

April 2016

Amends to reflect change to requirements on FDDs, requirements attached to Display Authorisations and preliminary planning requirements (Chapter 2 Part A), and amends to reflect changes in site assessment and display planning rules and new requirements on post event feedback and safety breach reporting (Chapter 3 Part A). Introduction of requirement to collect and communicate information on latent hazards within aircraft (Chapter 4 Part A). Further amends on DAE appointment and

competency and the requirements and processes attached to Display Authorisations and Display Authorisation renewals (Chapter 5 Part A).

All subsequent to CAA's review of Flying Display regulation conducted in 2015/6.

Edition 13, Amendment 2016/03

May 2016

Amends to adjust Minimum Separation Distance for light and rotary wing aircraft and to clarify requirements in relation to Display Authorisation revalidation and currency.

Amends subsequent to introduction of online application for Flying Display and special event Permissions. Minor addition to guidance on Risk Assessment

Edition 13, Amendment 2017/01

February 2017

Amends to reflect introduction of FDD accreditation scheme and inclusion of revised risk management guidance.

Edition 14

May 2017

A new edition, restructured to improve accessibility, update references and provide greater focus on Flying Displays by removing Part B of the existing document that related to other events not requiring CAA Permissions. Implementation of the CAA's air display review and organisational responses to AAIB recommendations have led to regulatory and policy developments relating to: Display Areas and public protection, FDD accreditation, Airborne FDDs (AFDDs), pilot declarations, FDD documentation checking requirements, warning and stop call guidance and Display Authorisation renewal.

Edition 14, Amendment 2017/01

May 2017

Minor clarifying amendments relating to definition of Aerobatic Manoeuvre, reporting of terminate calls, use of drones by the general public at displays and restrictions within the Display Area. Addition of a number of definitions to the glossary.

Edition 15

March 2018

Amendment includes minor clarifications and editorial changes throughout, the addition and amendment of certain definitions, details of the acceptability of certain foreign display authorisations, additional guidance for Flying Display and Special Event applications, additional information concerning military participation, further secondary spectator considerations, additional hazardous material information,

clarification concerning display practises on the day of an event, further details of FDD Accreditation, the provision of Deputy FDDs, reinforced requirement for submission of Flying Display Director Post-Display Feedback Form, updated information concerning the Police, the removal of reference to ORS4.1174 for display flight outside of the Display Area, revised requirements for DAEs, revised requirements for DAs, inclusion of a Suspension and Revocation procedure for FDDs, DAEs and DAs, amendments to DA Categories and Groups, incorporation of the Tyro DA scheme, Appendix B review, the removal of the 120 day notification period for RA(T)s for major events and further details concerning reporting and feedback.

Edition 16

January 2019

A restructured edition containing minor clarifications and changes throughout. Material specific to DAEs and DAs removed and incorporated into CAP 1724 'Flying Display Standards Document'. Appendices surplus to requirement removed. Introduction of editorial practises and definitions included in General Information chapter and incorporated throughout. For Private Flying Displays the introduction of the requirement for a FDD and risk assessment, along with the condition for a Display Pilot to hold a DA. Guidance for the application of Article 89 Dropping of Article Permissions and the associated operational restrictions. The requirement for certain key safety considerations to be included in all risk assessments. The requirement for reporting of RA(T) and airspace infringements reinforced. Further information concerning FDD currency, mentoring, shadowing and renewals.

Edition 17

January 2020

This edition incorporates feedback from the Flying Display community, mostly focussed on providing further clarity where required. Further guidance has been added to improve safety at twilight displays. Additional guidance has been given for displays that use airborne pyrotechnics to further protect Spectators and minimise the risk of ground fires. The guidance for formation briefing has been expanded and additional mandatory formation briefing requirements added. Additional guidance surrounding risk mitigation to As Low As Reasonably Practicable (ALARP), and amendments to risk categorisation have been made to Appendix A (Risk Assessment).

Feedback

The CAA seeks to continually improve its regulation and guidance and your feedback is helpful to us in doing so. If you have any comments on or suggestions about CAP 403 please send them to ga@caa.co.uk with subject line 'CAP 403 feedback'.

Terminology and Definitions

Throughout this CAP the following terms and definitions are used:

Term	Abbreviation	Definition
Aerobatic Manoeuvre		The definition of an aerobatic manoeuvre is as defined in Schedule 1 of the Air Navigation Order (ANO).
Airborne Flying Display Director	AFDD	A Pilot holding a UK Display Authorisation (DA) participating in their own single item Flying Display who is responsible to the CAA for the safe conduct of that Flying Display ¹ .
Aircraft Parking Area		An area used for the parking of aircraft to which the public has no access during the period of the display.
Airfield Boundary		The line delineated by the Airfield Boundary fence, or where no such fence exists, the area confined to that prepared and used solely for the purpose of ground manoeuvring of aircraft.
Air Traffic Services	ATS	References to 'ATS' contained in this CAP apply to all ground to air radio telephony transmission communications carried out.
Applicant		A person seeking the issue, renewal or upgrade of a CAA Permission, Exemption, approval or authorisation.
<u>Above Surface Level</u>	<u>ASL</u>	Reference to ASL in this CAP refers to the height above the surface being overflown
Car Park(s)		Where the words 'Car Park(s)' are used in the text of this CAP, they are intended to apply to Car Park(s) to which Spectators have access during the Flying Display and as such must be considered in the same manner as the Spectator Area.
Close Formation		Close Formation is defined as when an aircraft is flying in close proximity (usually within 50 metres) to another aircraft in such a manner as to require the following aircraft to take all external visual references solely from the lead aircraft.
Congested Area		A Congested Area is defined in Schedule 1 of the ANO ² .
Crowd Line		The line delineating the closest edge of any area, including Car Park(s), accessible to Spectators with respect to the Display Area / Display line.

¹ The Event Organiser (EO) and Airborne Flying Display Director (AFDD) might in some cases be the same person.

² For planning purposes and clarification, a golf course attached to a Congested Area is considered as part of that Congested Area and must be treated as such when considering overflight restrictions.

Term	Abbreviation	Definition
Danger Area		“Danger Area” means airspace which has been notified as such within which activities dangerous to the flight of aircraft may take place or exist at such times as may be notified
Display Area		The Display Area is the ground area footprint of the airspace within which displaying aircraft may be manoeuvred at a height below that imposed by SERA.5005(f)(1), SERA.5005(f)(2), subject to the limits of the Flying Display Permission, any further restrictions imposed by the FDD, and the pilot's <u>DA / Military Public Display Authority (PDA)</u> .
Display Authorisation	DA	A national document detailing the groups and categories of aircraft in which a pilot is authorised to display, together with any limitations and other specific endorsements.
Display Authorisation Evaluator	DAE	A person authorised by the CAA to conduct evaluations for the award of a Display Authorisation.
Display Item		A single, formation or group of aircraft, flying as one single display 'act' throughout.
Display Line or Display Axis		A line defining the track along which displaying aircraft may operate.
Display Pilot		A pilot who holds a Display Authorisation (DA) or exemption, issued by their National Aviation Authority, or an appropriate military Public Display Authority (PDA), or military Exemption, which allows them to participate in a Flying Display.
Display Routine		A series of linked manoeuvres to be performed during a Flying Display
Essential Personnel		A person or persons authorised and permitted to be within designated restricted areas, forward of the Crowd Line, during a Flying Display. Examples of Essential Personnel include members of Emergency Services, essential ground support crew, ATS personnel, the FDD and members of the FCC, refuelling operatives, barnstorming display act ground participants when in conjunction with their specific role and CAA FSOs whilst pursuant to their duties. NOTE: Once a specific duty has been completed, those personnel become non-essential and must re-locate to an area compliant with published Flying Display lateral Separation Distances.
Event Organiser	EO	The EO is the person responsible for all matters pertaining to the wider planning and execution of an event that includes a Flying Display and for the safety of the general public, both at the event and those affected by the wider impacts of the event.
Fédération Aéronautique Internationale	FAI	The world air sports federation.

Term	Abbreviation	Definition
Flying Control Committee	FCC	A group of suitably experienced persons assembled to assist the FDD in safety management of a Flying Display.
Flying Display		Any flying activity deliberately performed for the purpose of providing an exhibition or entertainment at an advertised event open to the public.
Flying Display Director	FDD	The person responsible to the CAA for the safe conduct of a Flying Display ³ .
Flying Display Director Mentor	FDDM	A FDD that has been accredited under the joint CAA / MAA FDD accreditation scheme so endorsed as to permit mentoring of aspiring FDDs.
Flypast		An aircraft flying, either singly or in formation, past a gathering of Spectators along a pre-planned route without manoeuvring, other than when necessary for safe and accurate navigation. Accordingly, this will not include Aerobatic Manoeuvres. A Flypast is considered to consist of one single pass unless otherwise specified on the appropriate Permission.
Flypast (Mil)		A Flypast (Mil) involves aircraft flying, either singly or in formation, over or past a gathering of Spectators along a pre-planned route without manoeuvring, other than when necessary for safe and accurate navigation. Accordingly, they will not include Aerobatic Manoeuvres.
Funeral Flypast / Funeral Flying Display		Flying activity performed on commemorative and 'in memorial' occasions. The terms 'Flypast' and 'Flying Display' in this context are as defined elsewhere in this section.
Military Aviation Authority	<u>MAA</u>	The military authority responsible for the regulation of military-registered air systems, and military Flying Displays.
Minimum Aerobatic Height		The minimum height above which the aircraft must be capable of complete recovery from an Aerobatic Manoeuvre. This will be the most restrictive of: <ul style="list-style-type: none"> ▪ The minimum aerobatic height specified in the Permission; ▪ The minimum aerobatic height quoted on relevant pilot's DA (in relation to the aircraft category being flown); or ▪ The minimum aerobatic height imposed by the FDD.
MOD Occupied Property		Any premises occupied by or under the control of the MOD or any other visiting military force.
<u>Minimum Separation Distance</u>	<u>MSD</u>	<u>The minimum separation, in all directions, between any part of an aircraft in flight and the ground, water or any obstacle.</u>

³ The Event Organiser and FDD might in some cases be the same person.

Term	Abbreviation	Definition
<u>Minimum Pyrotechnic Release Height</u>	<u>MPRH</u>	<u>The minimum height above surface level from which pyros may be ignited, released or emitting product such that any dross / embers are completely burnt out when reaching surface level.</u>
Non-Aerobatic Flying Display		A Non-Aerobatic Flying Display is defined for these purposes as a display made up of manoeuvres which do not require the pilot to exercise the privileges of an Aerobatic DA; where Aerobatic Manoeuvres are as defined in <u>Schedule 1</u> of the ANO.
Participant		A Flying Display or Special Event performer, or any person directly involved in the conduct of a Flying Display performance.
Permission		The document issued by the CAA permitting the proposed flying activity to take place.
Pleasure Flights		Any passenger flight starting from, or arriving at, the display site (or adjacent site) purely for the purpose of Commercial Air Transport pleasure flying on the day of a Flying Display or Special Event.
Private Flying Display		Any flying activity deliberately performed for the purpose of providing an exhibition or entertainment at a private event requiring a Permission to operate contrary to the requirements of <u>SERA.5005(f)</u> . (See also 'Flying Display' ⁴)
<u>Pyrotechnic</u>	<u>Pyro</u>	<u>Any article containing explosive substances, or a mixture of substances designed to produce heat, light, sound, gas or smoke or a combination of such effects through self-sustained exothermic chemical reactions.</u>
Regulatory Article 2335	<u>RA2335</u>	Regulation detailing the requirements for Flying Displays held over MOD Occupied Property and events over non-MOD Occupied Property where the only participants are military registered aircraft.
Role Demonstration	Role Demo	Any flying activity designed to demonstrate an aircraft's performance commensurate with that normally carried out during routine operations and training.
Separation Distance		The lateral distance between the displaying aircraft and Crowd Line.
Secondary Spectator		A person viewing a Flying Display from a location which has not been specifically designated for Spectators by the <u>EO</u> or FDD.

⁴ Where reference in this CAP is made to a 'Flying Display' the content applies also to a 'Private Flying Display'.

Term	Abbreviation	Definition
Special Event		Any flying activity deliberately performed requiring a Permission to operate contrary to the requirements of the ANO , the Rules of the Air or SERA . Special Events include Funeral Flypasts, the dropping of articles and can include film work or any other unusual activity ⁵ .
Spectator		A person attending a Flying Display specifically to witness the event.
<u>Spectator Area</u>		<u>An area specifically designated for Spectators by the EO or FDD and approved by the FDD for Flying Display safety purposes which includes all areas to which Spectators have access during the Flying Display.</u>
Static Aircraft Park		An area used for the parking of aircraft to which the public may have access.
Swept Wing Jet		<u>Any jet aircraft the CAA classifies as ‘Swept’ including, but not limited to, those where the wing leading edge is at an angle of 30 degrees or more from the perpendicular to the longitudinal axis.</u> ⁶
Tailchase		A Tailchase is defined as one or more aircraft following a leader through a series of manoeuvres.
Twilight		<u>The period from sunset to 30 mins after sunset; and from 30 mins before sunrise to sunrise, where sunset and sunrise are measured at surface level at the display location</u> ⁷ .
Tyro Display Authorisation	TDA	A display authorisation available to a newly qualified Display Pilot subject to the conditions detailed in CAP1724.

⁵ Special Event Permissions do not include aerobatics, unless otherwise stated

⁶ Classification of a particular aircraft type is the responsibility of the CAA.

⁷ Schedule 1 of the ANO refers to the definition of night.

General information

Introduction

Flying Displays and aerial Special Events form a significant part of the UK leisure industry. Organisation, administration and participation in displays needs careful consideration if the highest safety standards are to be achieved and maintained. This publication contains specific requirements and is intended as a code of best practice. It offers guidance material to enhance the safety of both the Participants and the Spectators.

Protecting the public is of paramount importance and as such any Participant or organiser of a Flying Display or Special Event is responsible for carrying out their tasks with the utmost professionalism and to the highest standards. Flying Displays and Special Events **must** be carefully planned both on the ground and in the air and nothing is to be conducted without careful thought towards ensuring that the risks to the general public, spectators and flying and non-flying participants have been considered and the activity is as safe as reasonably possible.

The impromptu, *ad hoc*, unrehearsed or unplanned **must** never be attempted.

Background

The Civil Aviation Act 1982 empowers the Civil Aviation Authority (CAA) to regulate civil Flying Displays within the United Kingdom in accordance with the requirements of the ANO. This publication sets out the safety and administrative procedures to be followed by organisers and Participants at such events.

Military Flying Displays are referred to in Article 86 paragraph 15 of the ANO. Military Flying Displays and Flypasts are conducted in accordance with Military Aviation Authority (MAA) [Regulatory Article 2335 \(RA 2335\)](#).

Guidance is also provided, beyond the statutory requirements, so that experience gained from past displays can be of use to those new to both the organisation and participation in such events.

Unless otherwise stated, nothing in this publication is intended to conflict with the ANO or other legislation, which, for the avoidance of doubt, **must** be regarded as

overriding. Compliance with this publication does not by itself indemnify any person or persons against liability for an accident or serious incident occurring.

Whilst every effort is made to ensure that all information is correct at the time of publication, the CAA reserves the right to amend this document as required to accommodate changes to the law, to correct errors and omissions, or to reflect changes in national policy and good practise.

Throughout this document the following editorial practises and definitions **shall** apply:

- **'Shall'** / **'Shall not'** and **'Must'** / **'Must not'** are used to indicate a mandatory requirement.
- **'Should'** is used to indicate strong obligation.
- **'May'** is used to indicate discretion.

Aeronautical Information Circulars (AIC) 'Regulation of Flying Displays' and 'Notification of Unusual Aerial Activities' are issued periodically to update the information in this publication.

Further useful information can be found at www.caa.co.uk/General-aviation/Displays,-events-and-activities/Flying-displays-and-special-events/

Safety Management

The **Event Organiser** or EO (as defined in this CAP) has overall responsibility for the planning, organisation and wider aspects of public safety at a Flying Display event.

The **Flying Display Director** or FDD (as defined in this CAP) is the person responsible for the safe conduct of the flying activity carried out pursuant to a Permission issued by the CAA.

For the avoidance of any doubt, the FDD must understand that they are responsible for the safety risks posed by the planning and management of Flying Display activity. They are also responsible for the oversight of pilots' performance at the display. They may be held accountable by the CAA for a failure to comply with the applicable regulations, the conditions of the Permission or the requirements set out in this CAP.

The EO is subordinate to the FDD in terms of managing and mitigating the risk posed by Flying Display activity.

The FDD must ensure that pilots' compliance with relevant regulations / conditions are monitored throughout the display and that unsafe displays are terminated. They should take into consideration the overall risk picture for the display and use all available resources to support their decision-making.

Display Pilots are responsible for ensuring that they comply with the Rules of the Air Regulations and the ANO, the conditions of their licence(s) and Display Authorisation, and the conditions of a Flying Display Permission issued by the CAA⁸. They will be accountable to the CAA for a failure to comply with any of the applicable regulations or conditions. Pilots are reminded that it is an offence under the ANO to recklessly or negligently endanger any person, property or aircraft.

Any EO, FDD or pilot that is unsure about their safety responsibilities at a Flying Display should contact the [CAA GA Unit](#) to clarify the position.

Reporting

Open and honest reporting is an important part of an effective safety management system; this allows all those involved in Flying Displays to learn from others' incidents in order to prevent accidents in the future. The CAA applies a just culture approach to reporting that provides protection and confidentiality to anyone that reports a safety issue. Accordingly, the CAA welcomes open reporting from all involved in Flying Displays such that they can be shared with others. Furthermore, open reporting allows the CAA to focus its regulation and support efforts into the areas that will make the greatest difference.

Any observation, incident or issue can be reported, no matter how small or insignificant it might seem, and can cover aspects such as Human Factors, concerns over performance, near misses or issues that might have led to an incident or accident. Although FDDs **must** submit [SRG1305 / Form 4](#), the joint CAA / MAA 'Flying Display Director Post Display Feedback Form', the same form **may** be used by anyone wishing to report an issue in the interests of Flying Display safety. All

⁸ Applicable also to aircraft limitations and conditions as attached to a Certificate of Airworthiness or Permit to Fly.

reports will be treated confidentially, and all personal information will be removed during any follow up to protect the reporter.

Participants, organisers and supervisors are also encouraged to report any incidents or examples of errors involving human factors that occur during a display to [CHIRP](#) who have a dedicated Flying Display reporting stream designed to promulgate to the wider community any lessons learned that could be of benefit to others.

Chapter 1

Flying Display legal requirements

Article 86

- 1.1 The Air Navigation Order (ANO) defines a Flying Display as any flying activity deliberately performed for the purpose of providing an exhibition or entertainment at an advertised event open to the public. Article 86 details the regulations for both the Flying Display Director (FDD) and participating Display Pilots at such an event. The FDD **must** obtain, in writing, a Permission to hold the event from the CAA and to participate in the event, civilian Display Pilots **must** hold a Display Authorisation (DA) or a DA Exemption.
- 1.2 Before a Permission can be issued, the CAA **must** be satisfied that the FDD is **a person who is fit and competent as an FDD, having regard in particular to their previous conduct and experience, their organisation, staffing and other arrangements, to safely organise the proposed Flying Display**. To this end, the FDD is required to provide such evidence and undergo such tests and examinations as the CAA **may** require of them.
- 1.3 Similarly, before issuing a DA or DA Exemption, the CAA **must** be satisfied that the pilot is **fit to hold the authorisation and is qualified by having the knowledge, experience, competence, skill, physical and mental fitness to fly in accordance with the authorisation**. To this end, the pilot **must** provide such evidence and undergo such tests and examinations as the CAA requires of them. Further details regarding DAs are contained in CAP 1724.
- 1.4 In deciding if an application for a Permission under Article 86 is required, the FDD **should** note that the ‘open to the public’ requirement is the principal requirement rather than the ‘advertised’ element. If the general public are permitted onto the site for the purposes of witnessing a Flying

Display, with or without payment, an Article 86 Permission will be required.

- 1.5 AOC Emergency Service Companies **may** be issued exemptions from the provisions of Article 86 of the ANO 2016 (as amended) for the purpose of Emergency Services Role Demonstrations at UK offshore sites and / or UK onshore sites pre-notified to the CAA Flight Operations Inspectorate (Helicopter) Section⁹.

Private Flying Displays

- 1.6 A Private Flying Display is defined as any flying activity deliberately performed for the purpose of providing an exhibition or entertainment at a private event – that is one that is not advertised or open to the public, but which requires a CAA Permission or Exemption from any of the provisions of SERA. Private Flying Displays **must** be organised and supervised by a FDD / AFDD and the participating pilots are required to hold DAs.

Special Events

- 1.7 Flights at events that are not open to the public (Special Events) remain subject to the Rules of the Air Regulations and the Standardised European Rules of the Air (SERA). To hold such an event, an appropriate Permission is to be sought from the CAA if there is a need to contravene any aspect of these rules (low flying for the purpose of a Private Flying Display for instance).
- 1.8 If it is intended to perform at such an event where a SERA Permission is not necessary, a NOTAM is highly recommended in order to notify other airspace users of this Unusual Aerial Activity. Display pilots / organisers can obtain a NOTAM Request Form by email to: AROps@caa.co.uk or by calling 01293 768202; this email / number is monitored Mon-Fri 0830-1630. NOTAM requests **should** be submitted as soon as practicable to ensure NOTAMs are promulgated in good time. In addition to the NOTAM

⁹ AOC Emergency Service Companies that hold Article 86 Exemptions may also perform Role Demonstrations (in accordance with the conditions attached to such Exemptions) at Flying Displays without being included as a Display Item with the written invitation of the FDD.

request, it is highly recommended that if performing at such an event, transponder equipped aircraft **should** transmit a conspicuity code (squawk) of 7004 unless otherwise directed.

Dropping of articles (Article 89 of the ANO)

- 1.9 The dropping of articles at events that are advertised and open to the public require an Article 86 Flying Display Permission in addition to the Article 89 Dropping of Articles Exemption unless:
- a) the articles to be dropped consist only of items not exceeding one half kilogramme in weight
 - b) the dropping of the articles is confined to within a delineated area clear of the assembled spectators
 - c) meteorological conditions are such as to allow flight under Visual Flight Rules
 - d) the articles are dropped during a single flypast
 - e) A risk assessment is submitted with the Article 89 application
- 1.10 Nothing in this paragraph applies to Article 89 Dropping of Article Exemptions for private occasions.

Aircraft Races and Contests

- 1.11 Aircraft races and contests, organised by officially recognised organisations, are specifically exempt from the requirements of Article 86 of the [ANO](#). However, where the public has access to the site of the race or contest, the organiser **should** comply with those parts of this CAP relating to public safety, particularly in relation to Minimum Separation Distances between aircraft, in flight and on the ground, and the public.
- 1.12 Consideration **must** be paid to low flying rules, overtaking, landing with occupied runways, etc and the appropriate permissions / exemptions obtained.
- 1.13 Aircraft races and contests **should** be organised and managed in line with the associated body's framework of rules and guidelines.

Fly-ins

- 1.14 CAA Permissions are not required for other flying events such as fly-ins, provided none of the Article 86 qualifying conditions are met and all flying activity is in accordance with the [ANO](#) and [SERA](#).

Military events, venues and military participation in civil Flying Displays

- 1.15 Flying Displays over MOD Occupied Property¹⁰ are regulated by the MAA and are not subject to an ANO Article 86 Permission¹¹. Participation by civilian pilots in such displays will be subject to compliance with the most restrictive limits contained within the relevant CAA CAPs and RA 2335.
- 1.16 Flying Displays over non-MOD Occupied Property involving only military registered aircraft are regulated by the MAA and do not require a CAA Permission to be issued pursuant to Article 86(1) of the ANO.¹²
- 1.17 Before any military aircraft can participate in a UK Flying Display, its participation **must** be approved by the MOD. In the case of UK military aircraft, it can be assumed that the required approval has been given by the MOD when the aircraft is allocated to the Flying Display by the relevant Service.

Foreign participation

- 1.18 DAs issued by other countries **may** be accepted by the UK CAA for pilots participating in Flying Displays in the UK where they provide a similar level of assurance to the UK system. The limitations imposed on pilots holding a DA issued in another country whilst displaying in the UK are the more restrictive of the limits specified in the pilot's DA or the limits imposed in the Flying Display Permission or by the FDD.
- 1.19 Confirmation of the acceptability of holders of any other non-UK DA **should** be directed to the UK [CAA GA Unit](#).

¹⁰ Including MOD owned property

¹¹ Article 86(15)(a).

¹² Article 86(15)(b).

- 1.20 Non-UK Pilots **may** hold, if they wish, a UK DA provided they meet all the requirements specified in [CAP 1724](#) and have been recommended to the CAA by a UK DAE. The limitations of the UK DA will apply to Flying Displays flown in the UK.
- 1.21 Alternatively, for non-UK pilots who do not hold a UK DA or a national DA acceptable to the UK CAA, FDDs can apply for a UK DA Exemption using Form SRG1328. Provided an application is acceptable, and depending on the suitability of the candidate and the supporting information, the CAA may mandate a practice / validation flight prior to any public display / DA Exemption issue. Form SRG1329 must be submitted for practice / validation flights mandated by the CAA.

Foreign military participation

- 1.22 Foreign military participants require the specific approval of the MOD before participating in a UK Flying Display. FDDs **should** seek early clarification from the [MAA](#) if they believe that such Display Items will be participating in their Flying Display; refer also to [Regulatory Article 2335](#).
- 1.23 In some countries, military-registered aircraft may be operated by non-military organisations and civilian-registered aircraft may be operated by military organisations. In both cases, the [MAA](#) and the [CAA GA Unit](#) **must** be consulted for clarification as to whether a form of military Public Display Authority (PDA) / validation or civilian DA / validation is required prior to participating in a UK Flying Display.

Civil foreign registered aircraft

- 1.24 Where civil foreign registered aircraft are carrying passengers for valuable consideration into an airfield hosting a Flying Display, a Permission under Article 250 of the [ANO](#) **may** be required. The FDD **should** advise the operators of such aircraft to contact the UK CAA ([foreign carrier permits](#)) for further detail or clarification.
- 1.25 Civil foreign registered aircraft, other than those covered by [ORS4 1249](#), operating on any form of non-standard or restricted Certificate of Airworthiness (equivalent to the UK Permit to Fly) require an exemption to

fly in UK airspace. Exemptions are issued by the CAA [Applications and Approvals Department](#). In addition, for ex-military aircraft with a Maximum Take-off Mass Allowed (MTMA) in excess of 2730kgs, a degree of equivalence with BCAR A8-23/24/25/26 and [CAP 632](#) will be required. Details on making an application for an exemption to fly in UK airspace can be obtained from the [Applications and Approvals Department](#).

Further reading

- 1.26 In addition to the regulation referred to in this chapter, recommended further reading includes:

Rules of the Air Regulations 2015

Rule 4 Aerobatic flights

Rule 10 Landing and taking off

Standardised European Rules of the Air (SERA)

SERA.5005 Visual Flight Rules

SERA.3210 Right-of-Way

Civil Aviation Authority Regulations 1991

Regulation 6 Guidance for the CAA Safety and Airspace Regulation Group (SARG) on conduct of reviews of decisions or proposals made by SARG

Chapter 2

Applying for a Flying Display or Special Event

Applying for permission

2.1 This chapter deals with the process and information required by the CAA when applying for a Permission to carry out a Flying Display or Special Event. Applications do not necessarily need to be made by EOs or FDDs, however, it should be noted that the CAA will correspond directly with the FDD, or an agreed designated assistant, regardless of applicant, concerning any issues raised during application processing for an Article 86 or Private Flying Display¹³ Permission.

2.2 An application for a Flying Display or Special Event Permission is made online by either visiting the [CAA website](#) or selecting this [link](#). **All** applications require:

- a) A colour 1:50,000 scale Ordnance Survey map extract.
- b) A list of participating aircraft. This list **may** be entered on the on-line form itself or by using an [aircraft Display Item schedule](#) which can be completed separately and uploaded with the application.

In addition, applications for Article 86 Flying Displays and Private Flying Displays will also require a fully completed Flying Display Risk Assessment. Further guidance on the production of a suitable Flying Display Risk Assessment can be found at Appendix A.

2.3 If applying for an Article 86 Flying Display or Private Flying Display Permission, the application incorporates a declaration in which the FDD undertakes that the Flying Display will be conducted in accordance with the relevant provisions of this CAP. Additionally, the FDD certifies that a process is in place to communicate information concerning the handling of potential hazardous materials or equipment contained within performing aircraft [to Emergency Services](#) in the event of an incident.

¹³ As defined in this CAP.

- 2.4 If applying for an Article 86 or SERA Permission to conduct a Flypast, unless otherwise informed, the CAA will issue a Permission for a single Flypast as defined in this CAP. If multiple Flypasts are required, details of the intended number of passes must be entered in the 'display item description' area of the online application form so that any Permission can be issued accordingly.

Identifying the permission required

- 2.5 The following tables can be referred to when determining the type of Permission required for a proposed event. It should be noted that the CAA will not issue an Article 86 or SERA Permission for any event over or centred on MOD occupied property or for any event over civilian land where the only participants are military registered aircraft.

Events Over Civilian Land								
Type of Event	Advertised and open to the public				Not advertised and private			
Applicable Permission	Article 86 Permission				SERA Permission			
Permission in place	Yes		No		Yes		No	
Registration of aircraft	Mil Reg	Civ Reg	Mil Reg	Civ Reg	Mil Reg	Civ Reg	Mil Reg	Civ Reg
Permitted Activity	Display Flying Role Demo Flypast (Mil)	Display Flying Flypast	Role Demo Flypast (Mil)	None (regardless of height)	As per Permission	As per Permission	Role Demo Flypast (Mil)	In accordance with ANO/SERA
Regulation (most restrictive of)	CAP 403 RA 2335	CAP 403	RA 2335	N/A	CAP 403 RA 2335	CAP 403	RA 2335	ANO/SERA

Events Over MOD Occupied Property				
Military Regulated				
Registration of aircraft	Military Reg		Civilian Reg	
Type of Event	Flying Display	Other Event	Flying Display	Other Event
Permitted Activity	Display Flying Role Demos Flypast (Mil)	Role Demos Flypast (Mil)	Display Flying Flypast	As per the ANO/SERA
Regulation (most restrictive of)	RA 2335	RA 2335	RA 2335 CAP 403	ANO/SERA

The Map

2.6 The colour 1:50,000 scale Ordnance Survey map extract **must** clearly show the event location and the layout of the site including:

- a) Boundaries of the Display Area
- b) Any relevant features within the Display Area, including but not limited to:
 - i) Buildings potentially occupied by non-essential personnel
 - ii) Areas where secondary spectators might assemble
- c) Spectator Areas and Car Parks
- d) Features outside of the Display Area that are put at increased risk as a result of the display taking place including, but not limited to:
 - i) Congested Areas
 - ii) Masts, railway lines, bridges and other local infrastructure
 - iii) Major / busy roads
 - iv) Areas where secondary spectators assemble

The following example shows a simple Display Area:

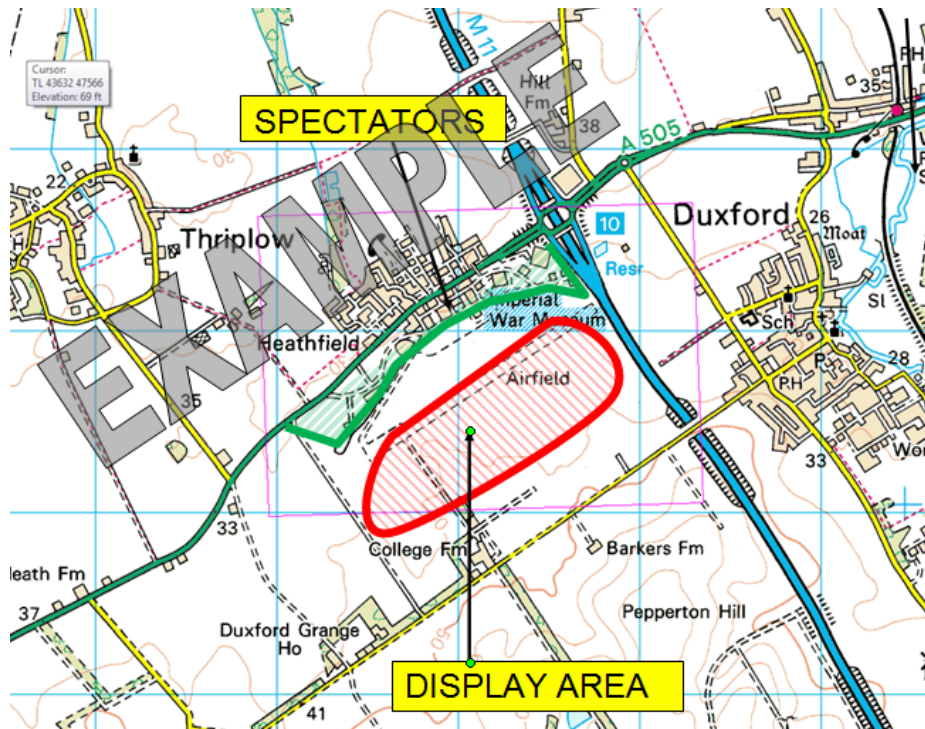

The following example illustrates a case where 'sub-areas' have been used.

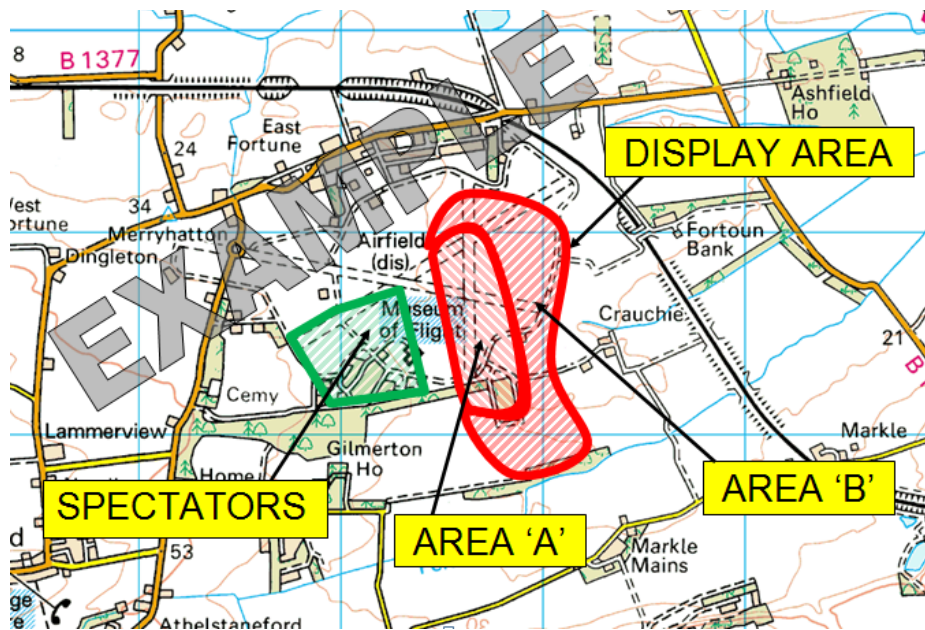

For further information on Display Areas and associated 'sub-areas' see Chapter 5.

Flying Displays and Special Events featuring only military aircraft

- 2.7 If your Flying Display or Special Event includes only military aircraft, you **must** notify the CAA separately using [DAP1920D: Request for Airspace Coordination and Notification - Air Displays](#) or [DAP1920F: Request for Airspace Coordination & Notification – Flypasts](#) as appropriate.

Charges

- 2.8 The actual charges payable are as published in the [CAA Scheme of Charges \(General Aviation\)](#).
- 2.9 The total payment due is automatically calculated whilst completing the [on-line application form](#) and the amount payable is quoted at the appropriate stage of the process. Payments can be made by credit or debit card.
- 2.10 Payment in full is to be made at the time of submission of the completed [on-line application form](#).

Flying Display charge bands

- 2.11 The amount payable is dependent on the number of chargeable Display Items, and a 'Display Item' is defined as 'a single, formation or group of aircraft, flying as one single display act' throughout¹⁴.

Exempt items

- 2.12 The following items are currently exempt from charges:
- a) Any race, rally or competition event
 - b) Any parachute display
 - c) Any balloon display
 - d) The dropping of ashes
 - e) The dropping of poppies for religious or ceremonial purposes

¹⁴ Random collections of aircraft are not considered to be a single Display Item unless they are flying together as a Formation.

Assessment of charges

- 2.13 If in doubt about the amount payable, please contact the [CAA GA Unit](#) (01293 573988).

Feedback

- 2.14 Feedback will be provided by email from the CAA following assessment of applications received for Article 86 Flying Display or Special Event Permissions within 7 days of receipt.

Chapter 3

Application Timescales

Notification to the CAA

- 3.1 The smooth and expeditious planning for a Flying Display, or any other Special Event, requires that various applications are made to the CAA within an appropriate timescale. These timescales are dictated by the requirements of the CAA to discharge their obligations to third parties, to achieve preparation of appropriate documentation including various regulations in the case of a Restricted Area (Temporary) (RA(T)) and to achieve satisfactory dissemination of the information to all interested parties. The timescales given below are the **minimum** required. Where possible, and certainly in the busy summer months, applicants are requested to submit applications with as much time prior to their event as possible.

90 days prior to the event

Restricted Area (Temporary) (RA(T))

- 3.2 Applications **should** be made to AROps@caa.co.uk in respect of a RA(T) for all events at least 90 days prior to the event¹⁵.
- 3.3 RA(T)s **may** be available for any Flying Display sited at natural choke points, in otherwise unprotected airspace such as coastal events or where the size and nature of the event warrant the setting up of a RA(T). EOs **should** contact AROps@caa.co.uk for guidance.

¹⁵ RA(T)s are automatically provided for the Royal Air Force Aerobatic Team (RAFAT) The Red Arrows and other major military Formation Display Teams but only for the duration of their display plus a small margin.

60 days prior to the event

Air Traffic Service arrangements

- 3.4 If it is intended to establish a Temporary Air Traffic Control (ATC) Unit at an event, the provider of ATC **must** be nominated and is required to apply to the appropriate CAA Air Traffic Management (ATM) regional office.
- 3.5 Established ATC Units intending to facilitate a Flying Display or Special Event that involves any new, or significant changes to established ATM arrangements at their units **should** notify their ATM regional office.
- 3.6 EOs who wish to provide a Flight Information Service (FIS) at a temporary site, or an established site not normally providing a FIS, are required to apply to the appropriate CAA ATM regional office and also submit a completed form [OfW586a](#) to Ofcom, FAO Spectrum Licensing (Aeronautical).
- 3.7 If an EO is intending to provide a FIS, procedures for safe and efficient management of flights **shall** be collated and submitted. Guidance for the format of the local instructions is detailed in [CAP 797](#) Flight Information Service Officer Manual.
- 3.8 A copy of the proposed Manual of Air Traffic Services Part 2 (MATS Part 2) **should** be submitted to the CAA ATM Regional Office as soon as possible but no later than 60 days before the event. Guidance on the format of the MATS Part 2 is provided in CAA [CAP 670](#).

Frequency allocation

- 3.9 A request for a frequency is integral to the [ANO](#) approval process. FDDs seeking approval are advised to apply as early as possible but on no account later than 60 days prior to the event. Initiation of the frequency allocation process is achieved through submission of form [OfW586a](#)

Aerodrome licence

- 3.10 Where the event is held at a licensed aerodrome the licensee remains responsible for ensuring that the conditions of the aerodrome licence are not contravened. If any such condition is likely to be contravened then

discussion **must** take place between the FDD, the Aerodrome Licensee and the CAA (aerodromes@caa.co.uk) at least 60 days prior to the event.

- 3.11 In the case where a temporary aerodrome licence is required, an application **must** be made to the CAA (aerodromes@caa.co.uk) at least 60 days prior to the event on Form [SRG 2003](#). Further information can be obtained from the CAA (aerodromes@caa.co.uk) and [CAP 168](#) Licensing of Aerodromes.

42 days prior to the event

Notification to the CAA GA Unit and CAA Airspace Regulation Department

- 3.12 **It should be noted that it may not be possible for the CAA to process applications and issue the required Permission with less than 42 days' notice.**
- 3.13 To discharge its obligations and issue the necessary Permissions or Exemptions, the [CAA GA Unit](#) and [Airspace Regulation Department](#) require full details of the event, including press or practise days.
- 3.14 Complete [applications](#), including map, Risk Assessment (if required), details of display [items](#) (as known) and appropriate payment (by credit / debit card) **should** reach the [CAA GA Unit](#) at least 42 days before the display date.
- 3.15 If the event consists of, or includes, military aircraft carrying out a Flying Display or [military](#) Parachute Display Teams the FDD **must** complete and submit form [DAP1920D](#) no later than 42 days before the event.
- 3.16 It is appreciated that FDDs might not have complete details of the participating [display items](#) this far in advance. The [CAA GA Unit](#) and [Airspace Regulation Department](#) will, therefore, accept forms where the participating aircraft section is still incomplete to allow processing to start. The full list of aircraft **must** be [submitted](#) as soon as it becomes available.

30 days prior to the event

Air Traffic Service personnel

- 3.17 Air Traffic Control Officers (ATCOs), or Flight Information Service Officers (FISOs) intending to provide an ATS at a Flying Display or Special Event based at a temporary site, or a site not normally providing the service intended **must** ensure that they:
- a) Provide a minimum of 30 days' notice to the appropriate Principal Inspector (ATM) specifying the type of service they wish to provide, confirming their licence details and requesting examination dates
 - b) Submit completed Forms [SRG 1411b](#) or [SRG 1414](#)
 - c) In the case of ATCOs, comply with the relevant requirements of [CAP 1251](#).

14 days prior to the event

Military aircraft

- 3.18 If your event consists of, or includes, military aircraft Flypasts you **must** complete and submit form [DAP1920F](#) no later than 14 days before the event.

CAA GA Unit

- 3.19 Providing **complete** and **accurate** applications for either Article 86 Flying Displays or Special Events have been received by the [CAA GA Unit](#) no later than 42 days prior to the event date, the appropriate Permissions **should** be issued no later than 14 days prior to the event. However, for **late applications and those requiring extensive correspondence due to being incomplete or inaccurate on receipt**, this **may** not be possible.
- 3.20 It is recommended that applicants contact the [CAA GA Unit](#) if the required Permission has not been received 10 days prior to the proposed event.
- 3.21 With the exception of ashes drops and funeral Flypasts, **applications received within 7 days of the event date will not be processed**.

Chapter 4

Personnel

Lines of responsibility

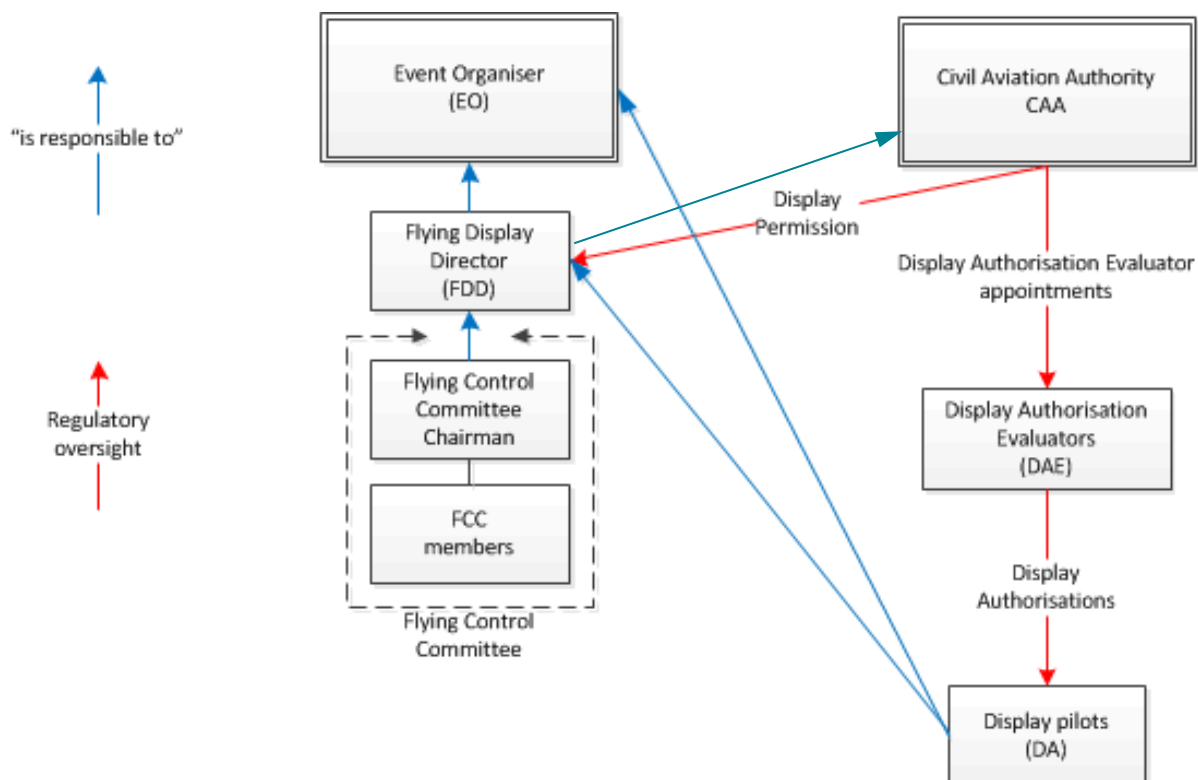

The Event Organiser (EO)

- 4.1 The EO is responsible for the planning, organisation and wider aspects of the Flying Display and any event surrounding it. The EO is ultimately responsible for the conduct of the event and the safety of the general public but is subordinate to the FDD in matters relating to air safety.
- 4.2 When an event involves a Flying Display the EO is responsible for risk management as it pertains to the wider event itself and **shall** have a working knowledge of this CAP.
- 4.3 Further guidance specific to EOs is contained in Chapter 7.

The Flying Display Director (FDD)

- 4.4 As defined by Article 86(1) of the ANO no person may act as the organiser of a Flying Display (FDD) without first applying for and obtaining the Permission of the CAA for that display.
- 4.5 The FDD is the person responsible for the safe conduct of the flying activity carried out pursuant to that Permission, and for compliance with the conditions contained within it¹⁶.
- 4.6 For the avoidance of any doubt, the FDD must understand that they are responsible for the safety risks posed by the planning and management of Flying Display activity. They are also responsible for the oversight of pilots' performance at the display. They may be held accountable by the CAA for a failure to comply with the applicable regulations, the conditions of the Permission or the requirements set out in this CAP.
- 4.7 The EO is subordinate to the FDD in terms of managing and mitigating the risk posed by Flying Display activity. Therefore, the FDD must have a comprehensive knowledge of this CAP and ensure that all aspects relating to the Flying Display activity are complied with.
- 4.8 At a Flying Display with up to 6 items, the role of EO and FDD **may** be combined. It is however recommended to separate these two duties where possible.

Airborne Flying Display Directors (AFDD)

- 4.9 AFDDs have all of the responsibilities of FDDs as set out above in addition to the airworthiness and safe conduct of the aircraft under their command.
- 4.10 AFDDs **shall** have a comprehensive knowledge of this CAP and comply with all the relevant aspects of it.
- 4.11 Further guidance for FDDs and AFDDs is contained in Chapter 8.

¹⁶ applicable also for Permissions issued for Private Flying Displays.

Flying Control Committee (FCC)

- 4.12 The FCC is appointed by the FDD and **should, whenever possible,** consist of a core of pilots with experience on the categories of aircraft being flown at the Flying Display. The FCC **may** be supplemented by other suitably experienced persons. Additionally, some members of the FCC **should** hold, or have held, a UK DA or UK PDA.
- 4.13 Further details on FCC's can be found in Chapter 8.

Flight crew

- 4.14 Civilian Display Pilots are responsible to the FDD for the safe conduct of the aircraft they are operating whilst performing at a Flying Display. They **shall** provide up-to-date documentation to the FDD pertaining to themselves and their aircraft and **must** ensure that their aircraft are airworthy, as required by the ANO. Further, any CAA Exemptions issued **must** be complied with when used and full documentation provided to the FDD.
- 4.15 Formation leaders are responsible for ensuring the safe flight of a formation. The leader must ensure that the pilots in the formation are suitably qualified and that formation flying activity is comprehensively briefed. Details regarding pilot qualification, currency and permissible formation flight can be found in CAP 1724.
- 4.16 Military Display Pilots are responsible to the FDD for the safe conduct of the aircraft they are operating whilst performing at a Flying Display. Military Display Pilots are approved and authorised by the MOD and are responsible for complying with any military specific limitations or regulations.

Chapter 5.

The Flying Display – planning and categorisation

Site assessment

- 5.1 Where the Flying Display is held at a licensed aerodrome, the aerodrome licensee, their representative or the aerodrome operators (if the aerodrome is unlicensed) **must** be involved at all stages of preparation for the Flying Display.
- 5.2 While many Flying Displays and Special Events are held at licensed aerodromes and can take advantage of facilities already available, many are staged at other sites. In assessing any proposed site, the following aspects **should** be taken into consideration:
- a) The suitability of surfaces used by aircraft for take-off, landing and taxiing
 - b) The take-off and landing distances available and required
 - c) Obstructions in the vicinity with regard to the aircraft types which are expected to take part
 - d) The proximity of Congested Areas.
 - e) The proximity of any sensitive or restricted areas. Local Police should be able to advise on such areas
 - f) The presence of livestock or wildlife conservation areas. The local branch of the [National Farmers' Union](#) can often help in identifying the owners of particular fields
 - g) The proximity of controlled airspace, aerodromes, heliports, helipads, airstrips, microlight sites, ballooning sites, parachuting, hang gliding, gliding, ridge soaring, paragliding sites, danger areas, firing ranges, model aircraft flying sites and visual reference points
 - h) The availability of clear entry and exit routes for on and / or off-site Emergency Service vehicles appropriate to the scale of the event

- 5.3 In assessing the suitability of a possible display site consideration **should** be given to the aircraft types intended to participate with specific regard to the ground area and vertical space likely to be required.

Spectator areas and car parks

- 5.4 Sites for Spectator Areas and Car Parks require careful selection. Any area to which spectators have access **must** never be located closer than the appropriate Separation Distance to the planned Display Area or lie underneath it.
- 5.5 Normally Spectator Areas and Car Parks will be confined to one side of the site thus allowing aircraft maximum freedom of movement on the other side.
- 5.6 If no practical alternative exists, Spectators' vehicles and visiting aircraft **may** be parked under the Display Area provided the EO and / or FDD does not permit access to these areas by the public for the duration of the Flying Display.
- 5.7 Spectator Areas and Car Parks **must** be sited away from taxiways and runways and so arranged that no part of a taxiing aircraft passes within 10 metres of the Spectator Area or Car Park. This distance will need to be increased significantly if Spectators are positioned behind or close to areas where aircraft are using significant amounts of power, such as ground running of engines (particularly in the case of high powered aircraft and large helicopters) and turning.
- 5.8 Spectators **must not** be allowed closer than 15 metres to any fixed refuelling area, nor closer than 15 metres radially from any fuelling or venting point on an aircraft or bowser whilst refuelling is being carried out.

Drones and balloons

- 5.9 Gas-filled toy balloons when released are a potential hazard to aircraft and the sale of such is not to be permitted in public enclosures.
- 5.10 Existing legislation provides that unmanned, gas-filled advertising balloons **must not** be flown in captive flight at or near an aerodrome without written Permission from the [Airspace Regulation Department](#). Any such balloon, or other obstruction with vertical extent such as tethered hot-air balloons and bungee jumping cranes, **must** be lowered to ground level during the period of the display.
- 5.11 The use of drones (UAVs) by the general public at Flying Displays poses a possible risk to aircraft and **must not** be permitted. Consideration **must** be given to raising public awareness of their legal responsibility and the importance of compliance. Possible measures include signage, information on tickets, social media and advice from the commentator. Members of the event staff and attending Emergency Service officers **should** be briefed to intervene as appropriate if drone operation is suspected or observed. Additional information can be found on the CAA website at <http://www.caa.co.uk/Consumers/Unmanned-aircraft-and-drones/> and at [Dronesafe](#) where a simple 'Drone Code' can be found. For relevant legislation refer to Articles 94 and 95 of the ANO.

Commentator and public address systems

- 5.12 A public address system covering the Spectator Area is essential. Such a system, when installed, **must** be audible throughout the whole Spectator Area.
- 5.13 A robust means of communication between the FDD and the commentator **must** be in place in order to communicate any programme changes, important messages or rapidly broadcast any emergency information to the public. Ideally the commentator and the FDD will be co-located.

- 5.14 If an emergency arises, the commentator will be essential in crowd control. FDDs **must** ensure that the commentator is in possession of a pre-scripted emergency message covering major emergencies.

Secondary spectator considerations

- 5.15 It is important to consider at the planning stage the likelihood and management of areas of potential secondary spectator build up, along with actions that can be put in place to help prevent such gatherings. Examples of possible actions include agreements with local landowners, road and footpath closures, the screening of vantage points, signage, articles in local newspapers and public forums, on the day patrols, etc.

Parking and ground manoeuvring of aircraft

- 5.16 Aircraft taking part in the Flying Display **should** be segregated from both visiting and static aircraft parks. Aircraft **may** be moved from these locations if they are required to take part in the Flying Display, however, aircraft in static parks **should not** start engines or APUs in these areas as they could present a hazard to the public.
- 5.17 Appropriate security **should** be in place to guard against interference with aircraft. Pilots **should** be advised to ensure that aircraft starting systems are isolated and access points locked if possible. Fire extinguishers **should** be readily available and aircraft **should** be parked so that fire vehicles can achieve easy access and move freely amongst them. Parking areas **must** be out of bounds to Spectators when aircraft engines are running or aircraft are taxiing.
- 5.18 Where possible, taxiing parallel to the Crowd Line, shutting down and towing or pushing into place **should** be considered during the planning of marshalling activities. Consideration **must** also be given to any planned arrivals of aircraft without brakes or possessing poor turning capability.
- 5.19 Helicopters **should**, if capable, only be permitted to ground-taxi. If unable to ground-taxi, they **should** only be permitted to hover-taxi in ground effect.

- 5.20 Effective barriers and marshalling arrangements are required to keep Spectators clear of aircraft manoeuvring areas at all times. Pilots and passengers of visiting aircraft **must** remain behind the Crowd Line during the period of the display.
- 5.21 In the interests of safety, smoking **must not** be permitted in Aircraft Parking Areas or Static Aircraft Parks.
- 5.22 Aircraft may take-off and land provided the runway centre line is at least 75 metres from the Crowd Line¹⁷. For multi engine aircraft consideration should be given to increasing this distance. The CAA GA Unit may grant a concession to allow a lesser distance where geographical or topographical features or the layout of the airfield restrict the distances available. The granting of any such concession is conditional on the type of aircraft involved.

Summary of separation distances for Flying Display planning

- 5.23 The following table summarizes the separation distances to be complied with when planning a Flying Display:

Summary of separation distance considerations for Flying Display planning	
Distance between spectators and any part of a taxiing aircraft	10 metres
Distance between spectators and any refuelling or aircraft fuel vent point	15 metres
Distance between Spectator <u>Areas</u> and runway centreline	75 metres

¹⁷ For formation departures, or departures from airfields with unmarked grass runways, the minimum distance is from the centre line of the ground track of the aircraft nearest the spectators.

Hazardous materials

- 5.24 All operators of aircraft used for flying displays are required to identify, and where practicable replace or remove¹⁸ any materials that might be hazardous to first responders and other personnel in the event of an accident.
- 5.25 Information of hazardous materials **must** be included on part 2 of [SRG1327](#) (Display Pilot's / Aircraft Owner's / Operator's Certified Declaration for submission to the FDD) and submitted prior to the display. Such information **must** include the Hazard Type and classification, PRT (for pyrotechnics), location, quantity and advise on safe handling along with contact details for specialist individuals or organisations who are available on the day of the event and capable of offering further advice. It is also highly recommended that this information is supplemented with Safety Data Sheets for each product (where available). FDDs are required to check this information and ensure that they have a means of communicating this information to the Emergency Services, should an accident or incident occur.
- 5.26 As military participants are not required to submit an [SRG1327](#) certificate, the FDD is to obtain details of any hazardous materials contained on or within the display aircraft along with contact details for competent persons and organisations as above. Military pilots can advise on the specific hazardous materials in relation to their aircraft.

Display area

- 5.27 It is important that the Display Area intended to be used is considered and decided on early in the planning stage; the Display Area **should** be

¹⁸ Any replacement or removal must be carried out with the support of the aircraft's Maintenance Organisation and / or Continued Airworthiness Management Organisation. Any removals which constitute a Design Change **shall** be approved in accordance with the aircraft's Continuing Airworthiness requirements.

suitable for all wind conditions in which the participating aircraft are likely to display.

5.28 The size of the Display Area, and the nature of its surroundings, should dictate the type of Display Items that are suitable for the venue. This evaluation may raise the question as to whether or not any form of Flying Display is suitable at the proposed site.

5.29 A cross section through a typical Display Area, adequate for the majority of Flying Displays is shown below:

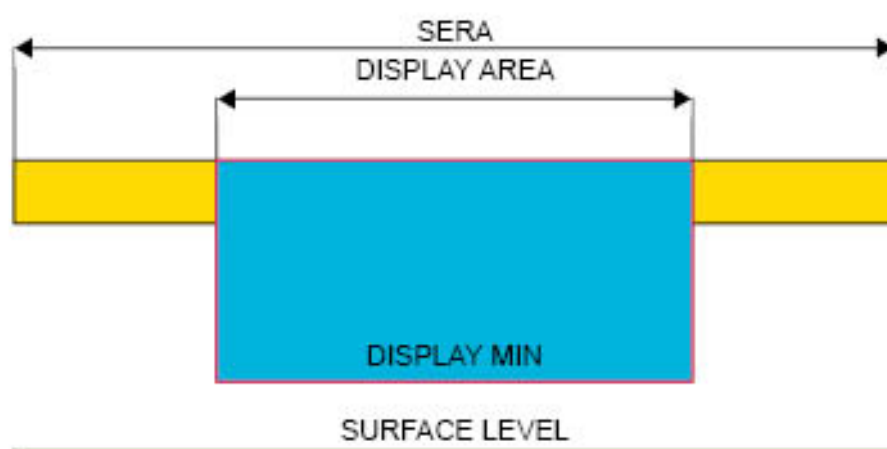

5.30 A Display Area can, if desired, be split into sub-areas (area 'A', area 'B', etc) with varying base minima. This allows the FDD to take different approaches to mitigating hazards within the areas and provide an area for transiting between SERA requirements and display minima. A cross section through such a Display Area is shown thus:

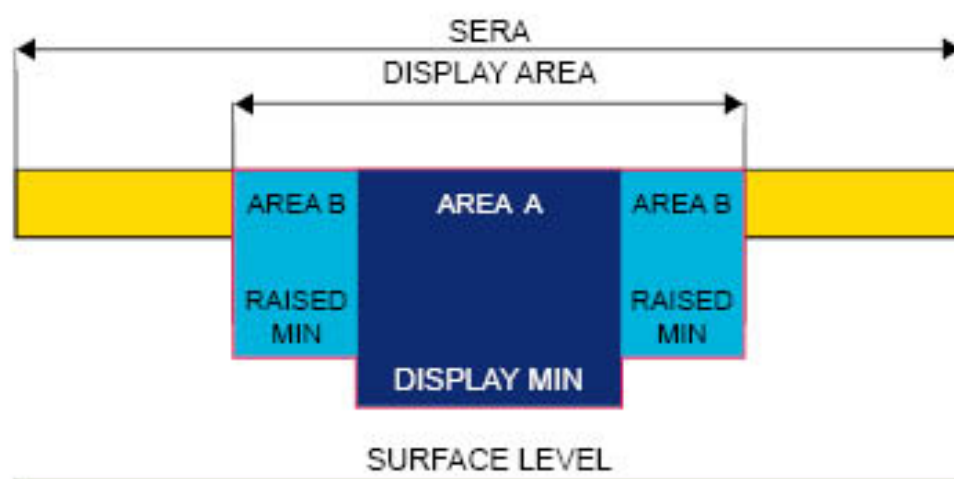

- 5.31 For standardisation, when using 'sub-areas', the inner most area where operation to display minimum is permitted **should** always be designated 'Area A'.
- 5.32 Deciding on the size and shape of the Display Area during the planning stage will help in highlighting any specific areas of concern such as major / minor roads, adjacent congested / built up areas, likely areas for gatherings of secondary spectators, terrain, etc. Once identified these issues will assist in the production of the Flying Display Risk Assessment and help define appropriate mitigating actions.
- 5.33 FDDs **should** endeavour, through mitigating actions and other arrangements, to produce a Display Area unhindered by 'avoids' so that participating pilots are free to focus on producing a smooth, flowing, safe display rather than being concerned about manoeuvring to avoid hazards¹⁹.

¹⁹ Note: These example maps are for illustration purposes only.

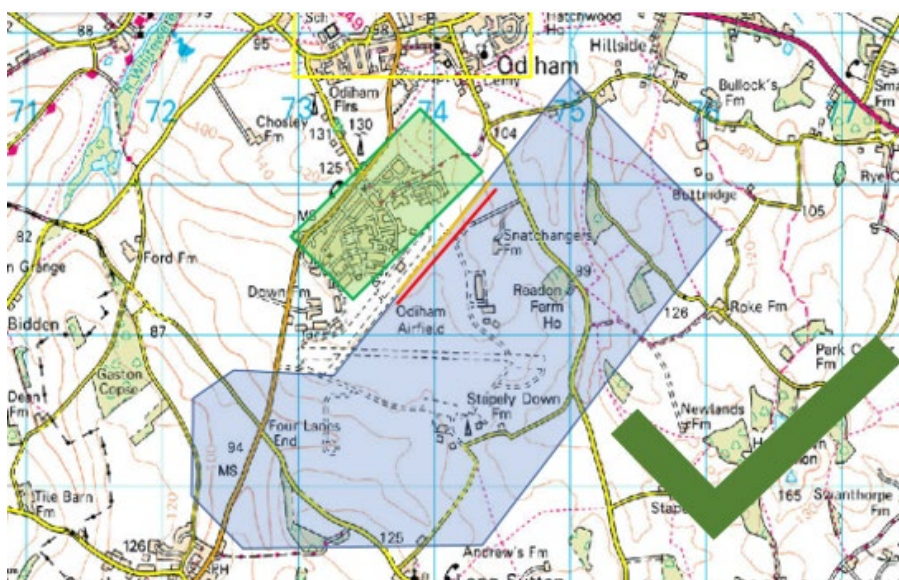
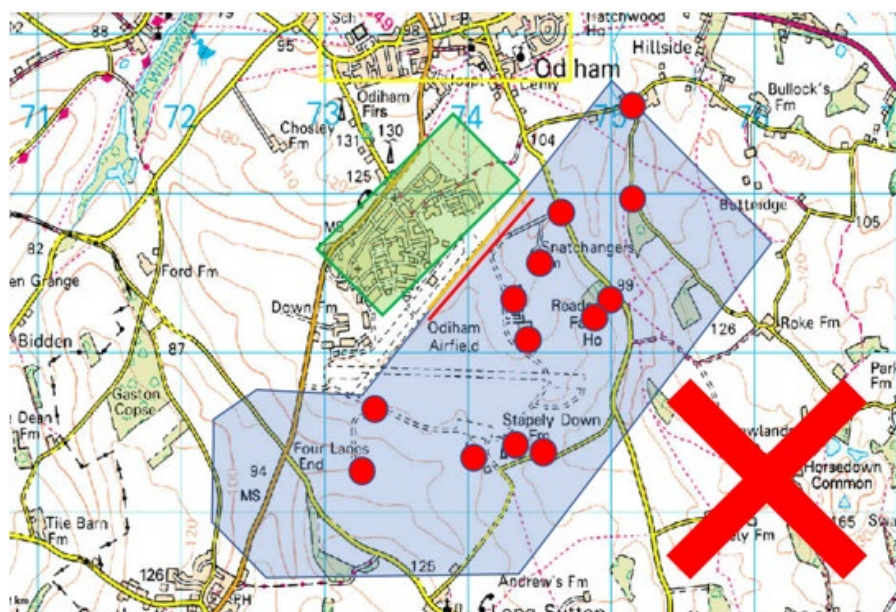

- 5.34 Once the Display Area has been promulgated, Display Pilots **should** review any aspects of their display that might not fit within the available Display Area and adjust accordingly. Where these changes constitute a variation to their 'practised display', they **should** ensure they have adequate opportunity to practise any modifications before the display. Pilots who are required to substantially alter or restrict their display **must not** be pressured into flying an unpractised display.

Separation Distances

5.35 Aircraft are not permitted to display above any point on the surface closer to any area occupied by spectators or their vehicles than that specified in the following table as appropriate to the display speed of the aircraft. For aircraft flying in formation, the distances are applicable to the aircraft performing nearest to the Crowd Line.

5.36 The minimum lateral Separation Distances between display aircraft and Crowd Line are as follows:

Type of aircraft	Type of display	Separation distance
All aircraft	All fixed and rotary-wing aircraft displays	230 metres
All aircraft	Speed greater than 300KIAS with velocity vector towards crowd	450 metres

For the following aircraft and activities, reduced minimum separations are permitted:

Type of aircraft	Type of display	Separation distance
Light Aircraft	MTOM less than 1200kg and speed less than 150KIAS	150 metres
Rotary-wing	Non-aerobatic flight and under-slung load operations	150 metres
VSTOL Aircraft	Vertical take-off and landing, and non-wing borne flight at low speed	150 metres
VSTOL Aircraft	Conventional wing borne flight	230 metres

5.37 If a formation consists of aircraft that are permitted to use different separation distances, the formation leader must ensure that the aircraft closest to the crowd line maintains the most restrictive separation distance.

5.38 The speed ranges given above are the speed of the aircraft at any particular time during the display. The pilot may use the separation

distance appropriate to the speed of the aircraft at the time of each manoeuvre / pass.

- 5.39 On a case by case basis, the CAA will consider applications to display at the reduced Separation Distance of 150 metres where MTOM of participating aircraft is greater than 1200kg but mass at time of display is less than 1200kg.
- 5.40 CAA Exemptions to the Separation Distances quoted in the table above have been issued. Holders of such Exemptions are permitted to operate to the Separation Distances contained therein provided the qualifying conditions are met. The FDD is responsible for assessing whether or not operation to the permitted Separation Distance contained on the Exemption is appropriate to the specific venue, therefore, operation to the Exemption minima requires the agreement of the FDD. If verification of an Exemption is required, the FDD **should** contact the [CAA GA Unit](#).
- 5.41 Manoeuvres such as high angle of attack passes, touch-and-goes and simulated go-arounds, or those which include a change of aircraft configuration, are to be flown in accordance with the Minimum Lateral Separation Distance table above.

Holding areas

- 5.42 During the planning stage, consideration **should** be given for the need to locate, identify and appropriately position aircraft holding areas. Holding areas **should** be away from controlled airspace, ideally positioned so as to avoid unnecessary over-flight of local sensitive or congested areas. Details of holding areas **must** be included in the display pilot's written brief and covered in display briefings.

Minimum heights

- 5.43 FDDs **should** consider imposing minimum height restrictions and avoids over sensitive local areas and Congested Areas. Details of any restrictions imposed **must** be clearly promulgated in the display pilot's written brief and included within the Flying Display Risk Assessment.

- 5.44 FDDs **must** ensure that pilots are advised of the minimum heights applicable at the Flying Display both in the display pilot's written brief and in display briefings.
- 5.45 Military pilots participating in a civil Flying Display **must** advise the FDD of their individual height minima. Article 86 of the [ANO](#) stipulates that military pilots are subject to the more restrictive of the limits imposed by [RA 2335](#) or the Flying Display Permission.

Categorisation of a flying display

- 5.46 The following table **should** be used by the FDD to categorise the Flying Display into the appropriate Tier²⁰. The FDD applying for a Flying Display Permission **must** be accredited to at least the same Tier as that of the display²¹. FDDs should note that the CAA may categorise the Flying Display at a different Tier on review of application.

No of Display Items	Low Complexity		High Complexity	
	Low Energy	High Energy	Low Energy	High Energy
1	Tier 1	Tier 1	Tier 1	Tier 1
2-3*	Tier 1	Tier 2	Tier 1	Tier 2
4-7	Tier 1	Tier 2	Tier 2	Tier 2
8-12	Tier 2	Tier 2	Tier 2	Tier 3
13+	Tier 3	Tier 3	Tier 3	Tier 3

* If the event consists of Flypasts only it can be considered Tier 1.

High Energy. Flying Displays **shall** be considered as High Energy if they contain aircraft >1200kg maximum take-off mass **and** a display at >150KIAS. All other displays should be considered Low Energy.

Complexity. FDDs **should** consider the following when making a judgement on whether an event is High or Low complexity:

²⁰ Any Flying Display with a High Energy display team consisting of 2 or more aircraft (e.g. RAFAT) shall be categorised as at least a Tier 2 Flying Display.

²¹ Emergency service Role Demos do not have to be included in the number of Display Items in the table above.

- a) **Airspace.** Consider the complexity of the airspace surrounding the display venue, including proximity to controlled airspace or areas with specific limitations that might affect the type of aircraft displaying
- b) **Geography.** Consider the difficulty of the terrain in addition to spectator and event layout
- c) **Built Up Areas.** Consider the proximity, density and size of adjacent built up and Congested Areas
- d) **Secondary Spectators / other members of the public.** Consider the likelihood and controllability of spectators gathering outside the designated Spectator Area and any effect the display might have on members of the public in the vicinity. Consider the proximity of major roads, railway lines and local infrastructure and how busy they are
- e) **Display Length.** Consider the effect of the Flying Display window on deconfliction issues, e.g. 3 items over 2 hours may be less complex than 3 items over 15 minutes
- f) **Display Team Size.** Consider the number and type of aircraft in a display team with respect to the size and nature of the display venue
- g) **Event Type.** Consider the type of event and how flying activity is integrated; is the Flying Display the focus of the event or just an additional attraction?

Use and allocation of radio frequencies

- 5.47 With the exception of small events, most Flying Displays will require the use of some level of radio communications. Details of the ATS aspects, allocation of frequencies and the use of frequencies can be found in Chapter 9.
- 5.48 Where feasible and within the constraints covered in Chapter 9, FDDs **should** endeavour to allocate a quiet frequency for use during the Flying Display with another frequency being available for administrative requirements and communication with non-display aircraft.

Airspace considerations

- 5.49 **NOTAM.** A NOTAM acts as a warning to other airspace users that an activity is taking place at a specified location for a specified time and may

by itself be sufficient for small events. A NOTAM extending 2000 feet vertically and 1.5nm horizontally will be automatically issued with each application. The FDD should consider whether this is sufficient to cover all planned activity. A space is provided on the application form to apply for any additional requirements.

- 5.50 **Restricted Area (Temporary) (RA(T)).** For larger or more complex events a RA(T) may be requested. It is important to ensure that the airspace requested meets the requirements of the event, allowing for practises and validations where appropriate. Careful planning of the size, shape and times of the RA(T) should provide adequate protection to participants whilst causing as little disturbance to other airspace users as possible.
- 5.51 Where the event is adjacent to controlled airspace, either laterally or vertically, it is important not to create an unintentional ‘rat run’ through which other aircraft may try to transit, and it may be preferable for the RA(T) to be hard up against the other airspace to prevent this.
- 5.52 Applications for RA(T) should be made to AROps@caa.co.uk within the timescale prescribed in Chapter 3.

Use of Transponder

- 5.53 To provide a level of conspicuity, it is highly recommended that transponder-equipped display aircraft should transmit the published conspicuity code (squawk) of 7004, unless otherwise directed.

Insurance

- 5.54 Although there is no requirement within UK civil aviation legislation for third party insurance cover of Flying Displays and other aviation events, EOs and Participants are strongly advised to give this particular aspect due consideration. Insurance cover is normally conditional on compliance with legal requirements, and violation of the law or the conditions of a Permission or exemption **may** render insurance invalid.
- 5.55 EOs and FDDs are strongly advised to seek professional guidance on liability aspects and to obtain advice from a reputable insurance broker

with aviation experience as to the appropriate level of third party liability coverage that should be affected.

- 5.56 The MOD will require EOs / FDDs to buy into the MOD insurance policy as a condition of allowing military aircraft to take part in the Flying Display.

Chapter 6

The Flying Display – Management

Display Line

- 6.1 Displaying aircraft perform relative to a Display Line which **must** be clearly identified. Where the Display Line is not clearly delineated by a paved runway or other obvious line feature it **should** be marked with day-glo pyramids or panels, whitewashed lines or by some other suitable method²².
- 6.2 Marking of more than one Display Line is at the discretion of the FDD. Ideally, two clearly defined lines, covering the Separation Distances most likely to be used by pilots during the Flying Display **should** be presented, allowing pilots to interpolate for intermediate distances.
- 6.3 FDDs **may** find it helpful to identify and mark a number of specific points (e.g. the display datum, if one is required) to help pilots position for the benefit of the spectators. The location and rationale for the marked points **should** be included in all pilot briefing material.
- 6.4 At sea-front displays it is essential that the Display Line is marked with hi-visibility buoys or marker floats. Additionally, unless a suitable feature cannot be clearly designated for the purpose, a distinctive buoy or group of buoys **should** be used to mark display datum, if a datum is required.

Display area restrictions

- 6.5 Within the Display Area, Display Pilots **must not** perform aerobatics, or fly below 500ft above the surface in non-aerobatic flight, over any building, vessel or vehicle which the Pilot in Command has reason to believe is

²² FDDs **should** be cognisant of recognisable features that might be a distraction to Participants when considering the requirement to mark the main display line, e.g. a non-parallel taxiway or runway.

occupied by non-essential personnel or known secondary spectator crowds.

- 6.6 Outside of the Display Area, aerobatic flight **may** be performed in accordance with SERA²³, to allow aircraft positioning / repositioning between manoeuvres.
- 6.7 Owners / occupiers of buildings located beneath a Display Area **may** be contacted and, if any building can be guaranteed to be unoccupied for the duration of the Flying Display, no restriction would be necessary provided full details of the hazard, risks and mitigations, including copies of the written confirmation from the owners / occupiers, are included in the Flying Display Risk Assessment.

Over-flight of spectators

- 6.8 Display aircraft are not permitted to overfly the Spectator Area unless with the specific written Permission of CAA GA Unit.
- 6.9 Permission **may** be granted for crowd rear arrivals provided the application is for an established Formation Team of similar powered fixed wing aircraft, supported by a comprehensive Flying Display Risk Assessment (updated annually).

Setting of minimum heights

- 6.10 Where Flying Displays are held at an aerodrome, the CAA will normally authorise the FDD to allow pilots to fly down to the minimum height specified in their individual DA.
- 6.11 Where Flying Displays are held away from an aerodrome, the CAA will impose a minimum height²⁴. This is usually 200 feet AGL over land and 100 feet ASL over water²⁵. In these circumstances the minimum height

²³ Flying Displays, air races and contests were removed from the scope of General Permissions concerning Exceptions to SERA minimum height requirements, in particular ORS4 No. 1174, following publication on 10 March 2016 of Air Accidents Investigation Branch Special Bulletin S1-2016.

²⁴ Note, although the heights quoted in this paragraph are the usual heights permitted, when assessing an application, the CAA may impose a higher minimum than those quoted.

²⁵ Displays during twilight will usually be limited by a higher minima

becomes the higher of either the CAA's imposed height or that specified in the pilot's DA. The FDD **may** impose higher minima if considered appropriate at a particular venue.

- 6.12 The minimum aerobatic height for civilian registered ex-military jet aircraft **must not** be lower than 500' AGL / ASL.
- 6.13 For Special Events requiring a CAA Permission, acceptable minimum heights will depend on the particular site, the pilot's experience and competence on type, the task, compliance with the Rules of The Air and the prevailing weather. The CAA will stipulate the specific minimum for the event on the Permission.
- 6.14 These minima do not absolve any individual(s) from compliance with the [ANO](#), Rules of the Air [Regulations](#) and SERA unless an exemption or Permission has been issued by the CAA. The [CAA GA Unit](#) will give advice on any particular circumstances.

Military participation

- 6.15 Pilots of military aircraft participating in a civil Flying Display **must** advise the FDD of their individual height minima²⁶. Outside the Display Area, military aircraft are permitted to fly in accordance with [RA 2335](#). FDDs remain responsible for approving military aircraft to use these limits and **must** consider whether they are appropriate for their event given the location and environment. Such activity **must** be included in the Flying Display Risk Assessment.
- 6.16 However, pilots of military aircraft are reminded that Article 86 of the [ANO](#) states that any conditions²⁷ subject to which the Permission for the Flying Display has been granted, also apply to military registered aircraft. FDDs **shall** inform pilots of military aircraft of any such conditions at the earliest

²⁶ Military aircraft may be permitted to operate to the height minima stipulated in RA 2335 provided Display Flying (as defined in RA2335) is in compliance with the appropriate PDA and subject to FDD approval.

²⁷ Such as specified avoids or additional minimum height restrictions.

opportunity. Such pilots are subject to the most restrictive limits of those imposed by a Flying Display Permission, [RA 2335](#), [their PDA](#) or [the FDD](#).

- 6.17 [UK Military Display Teams are permitted to display to their PDA limits in accordance with RA 2335, subject to FDD approval. Military Display Teams are therefore responsible for conducting their own Risk Assessments and shall inform the FDD at the earliest opportunity of any issues that may affect the Flying Display Risk Assessment. The FDD is responsible for incorporating any such amendments into the Flying Display Risk Assessment. Military Display Teams, particularly RAFAT, may request a different display orientation but if the FDD considers the proposed amendments to be unacceptable, the Display Item must not be permitted to display.](#)

Aircraft maximum speeds

- 6.18 An absolute true limit of Mach 0.90 or 600 kts, whichever is reached first, is not to be exceeded.
- 6.19 Civilian registered aircraft are not to exceed 250 kts unless a CAA Exemption has been issued to the operator **for that aircraft**.

Weather minima

- 6.20 Minimum weather conditions **must** be determined in advance, published and strictly observed. Flying Display absolute minima are contained in the table below:

Type of aircraft	Type of display		Weather minima	
			Cloud ceiling ²⁸	Visibility
VSTOL aircraft, rotorcraft and other aircraft with a stalling speed below 50 KIAS ²⁹	Flypasts, Non-aerobatic Flying Displays and Role Demos	Solo aircraft	500 feet	1500 metres
		Formations	500 feet	3000 metres
	Full aerobatic displays	Solo aircraft	800 feet	3000 metres
		Formations	1000 feet	5 km
All other aircraft	Flypasts, Non-aerobatic Flying Displays, 'flat' aerobatic displays and Role Demos	Solo aircraft	500 feet	5 km
		Formations	1000 feet	5 km
	Full aerobatic displays	Solo aircraft	1000 feet	5 km
		Piston Formations	1000 feet	5 km
		Jet / turboprop Formations	1500 feet	5 km

Higher limits may need to be imposed at certain Flying Display locations due to terrain or local conditions. Greater consideration may need to be given to visibility than cloud ceiling where there are few visual references or there is little or no defined horizon. This may be particularly pertinent at overwater display sites or during twilight displays.

6.21 FDDs **should** carefully consider the operating characteristics of participating aircraft which **may** necessitate specific increases in the above minima.

6.22 FDDs and pilots **should** also be aware of a condition known as the 'goldfish bowl effect' at over-water display sites. Where visibility is reduced, an impression can be created such that the sea and sky appear to merge. The subsequent loss of a good visual reference can make

²⁸ Cloud Ceiling is 'the height Above Ground Level (AGL) of the base of the lowest cloud covering more than half of the sky (BKN or OVC)'.

²⁹ This applies only to VSTOL aircraft operating in the VSTOL flight regime.

positioning difficult and compromise safety. Goldfish bowl conditions can also occur over land when sun position and reduced visibility make it difficult to determine the horizon. The effects can vary considerably with height and what appears a good horizon from the FDD / FCC location may not be useable at height.

- 6.23 It **should** be borne in mind that Participants **may** be further restricted by their licence or rating privileges.

Pyrotechnics used for ground special effects

- 6.24 The use of explosives for simulated ground bursts, smoke and other special effects **must** be strictly controlled by a competent person appointed by the EO in agreement with the FDD. Debris from such effects **must not** impinge on aircraft, Spectators or the runway / taxiways and to this end the scale and maximum heights of any effects **must** be known before the event. Briefings for ground officials and Display Pilots **shall** draw attention to the hazardous nature of such devices and **must** include details of positioning and timings of detonations with respect of manoeuvring aircraft, communication and emergency planning. Agreement in advance for the use of such devices during a Flying Display **must** be sought from all affected Display Pilots. The location of the explosives and safety radii, if appropriate, are to be out of bounds to all staff except those directly involved with their operation. Operatives **must** be appropriately authorised for such activity. If the launch position of any ground pyrotechnics is under the display area, consideration **should** be given to protecting the devices from inadvertent ignition due to falling embers released from any airborne pyrotechnic aircraft display.

Briefing

- 6.25 Regardless of the size of the Flying Display, the importance of a thorough, formal verbal briefing cannot be over-emphasised. No pilot is to take part in a Flying Display unless they have received a verbal briefing.
- 6.26 A comprehensive display pilot's written brief covering the arrangements for the flying programme **should** be circulated in advance to all

participating pilots, ATS provider, Pleasure Flight operators and those in charge of particular aspects of the display, such as safety services. A suggested minimum list of points which **should** be covered is given in Appendix B.

- 6.27 A formal verbal briefing **must** be given on each day of the Flying Display and at any rehearsal or press day, and all participants **must** attend if physically possible. The briefing **should**, as a minimum include all the points detailed in Appendix B.
- 6.28 Participants not operating from the Flying Display site, and those unable to attend the formal brief, **must** contact the FDD by telephone as close to their slot time as possible to obtain a full formal verbal briefing. A crib sheet identical to both FDD and participant, issued by the FDD as part of the comprehensive display pilot's written brief, **should** be used.
- 6.29 The FDD should keep a record of those pilots who have attended the formal brief as well as a record of the completion of any telephone briefs.

Display practises on the day of a Flying Display

- 6.30 Display practises at the event location, on the day of a Flying Display, can only be carried out prior to the arrival of any spectators on site and with the agreement and briefing from the FDD and EO. Practises of this nature require a SERA.5005(f)(2) Permission issued specifically for the purposes of display practise or rehearsal to be in place³⁰

Impromptu displays at Flying Displays

- 6.31 FDDs are to ensure that pilots of display aircraft do not carry out any form of impromptu display such as on arrival or departure.

³⁰ For clarification, it is permissible for display practises on the day of a Flying Display to be carried out away from the display area / event site in accordance with SERA.

Arrivals and Departures from Flying Displays

- 6.32 All Flying Display arrivals and departures **must** be in accordance with the aerodrome procedures and relevant regulation. Pilots **must not** be permitted to use the privileges of their DA / PDA during arrivals or departures unless arriving into a pre-organised display practise or display. Unbriefed and unexpected manoeuvres are equally, if not more, dangerous during arrivals and departures to and from a Flying Display as those carried out during a display. Pilots of civilian aircraft who do not hold a DA are not permitted to use the SERA 5005(f) Exemption over MOD Occupied Property.
- 6.33 The FDD **should** ensure that static display aircraft captains are briefed to comply with normal arrival and departure procedures to avoid any non-standard arrivals or departures.

Standard Warning and STOP calls

- 6.34 The FDD and / or FCC can assist the display pilot in assessing height and distance by using the warning calls detailed below. For example, if the FDD or FCC considers a pilot has flown a pass below minimum flypast height, a 'Too Low' call could help to ensure that subsequent passes are flown at the correct height and thus prevent repeated breaches or unsafe situations developing. However, if the FDD and / or FCC perceive a consistent breach of minima has occurred, have concerns that a limit is being exceeded, or have safety concerns that require a cessation of a display, they **must** make a 'STOP' call to halt the display.

6.35 The following Standard Calls and responses³¹ **shall** be used:

FDD / FCC Warning call	Pilot response
“(call sign) TOO LOW”	“ROGER (call sign)”
“(call sign) TOO CLOSE”	“ROGER (call sign)”
FDD / FCC Terminate call	Pilot response
“(call sign) TERMINATE”	“WILCO (call sign)”
FDD / FCC STOP call	Pilot response
“(call sign) STOP, STOP, STOP acknowledge”	“WILCO (call sign)”

NOTE: A STOP call **must** be made if a third Warning Call is required.

6.36 **Too Low call.** A ‘Too Low’ call **shall** be made at an appropriate time if the FDD / FCC assess that an aircraft has descended below the pilot’s DA minima or the minima in place for the Flying Display.

6.37 **Too Close call.** A ‘Too Close’ call **shall** be made at an appropriate time if the FDD / FCC assess that an aircraft has breached the minimum lateral separation distance appropriate to that display item.

6.38 **Terminate Call.** A Terminate call **shall** be made when it is necessary to discontinue a Display for a reason other than their fitness or competence (e.g. intruder aircraft, birds, etc). A Terminate call can also be used by a pilot to notify intention to halt a display if deemed necessary for any reason. At the discretion of both the FDD and the Display Pilot, the display **may** be resumed if safe to do so.

6.39 **STOP Call.** A STOP call **must** be made where primarily the FDD / FCC has a safety concern related to a pilot’s fitness or competence. When a STOP call is made, the pilot is required to stop their display and not

³¹ The purpose of a call and response is to verify that the required message has been received and appropriate corrective action by the pilot **should** therefore subsequently be expected.

recommence it. A STOP call can be made outright, or as a result of the need to issue a third warning call.

- 6.40 A fully briefed procedure is to be established and in place to communicate a STOP or Terminate call to any participating non-radio aircraft. Similar methods of communication **must** be considered to cater for a radio failure during a Display Routine. If an Aldis lamp signal is to be used for such a purpose, for standardisation, it is recommended that a 'steady white'³² signal be used. The same signal **may** be used to communicate both STOP and Terminate calls.
- 6.41 FDDs **should** consider the safest and most appropriate time to make a Warning, Terminate or STOP call and to not jeopardise safety by causing an unnecessary distraction for the pilot at a critical point during their display.
- 6.42 For Warning calls only, where the FDD / FCC considers, for flight safety reasons, there is no 'appropriate time' during the pilot's display, they **shall** verbally debrief the pilot once landed. In addition to the verbal debrief, the occurrence **shall** be recorded as a 'Warning call' on the joint CAA / MAA 'Flying Display Director Post Display Feedback Form' [SRG1305 / Form 4](#) along with a narrative detailing the debrief points and justification for withholding the call.
- 6.43 In the case of an obvious aircraft malfunction resulting in loss of control or other emergency, whether or not a PAN or MAYDAY has been transmitted, discretion and judgement **may** dictate that a display related safety call be an unwarranted distraction and wholly inappropriate.

STOP Call and safety breach reporting and procedures

- 6.44 The FDD **should** debrief the pilot following all standard warning and STOP calls. For warning calls other than a STOP call, the pilot **may** continue to exercise the privileges of their DA / PDA.

³² 'Steady white' light signal recommended as this is not a current ICAO light signal.

- 6.45 Following a STOP call to a civilian pilot, the FDD is required to report the incident to the [CAA GA Unit](#) by calling the telephone number quoted on the CAA Permission for the event as soon as is reasonably practical. This is a dedicated telephone number manned daily throughout the display season.
- 6.46 The following information **should** be included in any such call to the dedicated 'STOP call' telephone number:
- a) Event name and location
 - b) FDD's name and contact number
 - c) Time of STOP call
 - d) Display item / registration
 - e) Name of pilot and contact number
 - f) Details of debrief if carried out
 - g) A full account of the perceived breach
 - h) Contact details of FDD at any event the Display Pilot is known to be appearing at later the same day
- 6.47 When a STOP call is made, the relevant pilot's DA will be provisionally suspended. Details of the STOP call suspension and re-instatement procedure can be found in [CAP1724](#).
- 6.48 For military pilots where a STOP call is made, [Regulatory Article 2335](#) requires the pilot to inform their Aviation Duty Holder prior to conducting any further Display Flying³³. In this case the FDD is to debrief the display pilot and inform the CAA by way of the dedicated STOP call number.
- 6.49 Details of any Warning, Terminate or STOP calls issued **must** be included on the joint CAA / MAA 'Flying Display Director Post Display Feedback Form' [SRG1305/Form 4](#), regardless of whether the breach was by a civilian or military pilot.

³³ As defined in RA 2335.

Standard display calls

- 6.50 For clarification and to prevent confusion, it is recommended that the following call and read back is adopted to indicate when an FDD is content for a display item to begin its display.

ATS call	Pilot response
“(call sign) COMMENCE DISPLAY”	“COMMENCE DISPLAY (call sign)”

Carriage of persons onboard display aircraft

- 6.51 No persons other than minimum crew, as detailed in the aircraft Certificate of Airworthiness or Permit to Fly, are permitted onboard a civil registered aircraft during a Flying Display unless the prior written Permission of the [CAA GA Unit](#) has been obtained.

Displays by Air Operator’s Certificate (AOC) operators

- 6.52 Displays by AOC operators i.e. large transport aircraft, will normally be conducted under an exemption from the need to hold a DA issued by the [CAA GA Unit](#). The requested display profile is to be submitted in advance to both the [CAA GA Unit](#) and the assigned CAA Flight Operations Inspector (FOI) in the form of a Captain’s brief. The exemption will be issued only after the assigned FOI has agreed the content of the Captain’s brief.
- 6.53 Passengers are not to be carried during a Flying Display by AOC operators. However, additional flight crew or specialist maintenance personnel **may** be carried provided that a recommendation by the assigned FOI is made to, and accepted by, the [CAA GA Unit](#).
- 6.54 Formation flights by large Commercial Air Transport aircraft will not normally be permitted but specific applications will be considered on their merits.
- 6.55 AOC Emergency Service companies **may** be issued with Exemptions from the requirement for the Pilot in Command to hold a DA in accordance with the provisions of Article 86 of the ANO. Before a DA Exemption can

be considered for an AOC operator, the proposed Display Routine / Role Demonstration **must** be approved and recommended to the [CAA GA Unit](#) by the assigned CAA Flight Ops Inspector. The Display Routine / Role Demonstration **must** be included in the AOC Emergency Services Company Operations Manual. Confirmation that such an Exemption is held, and that any Display Routine / Role Demonstration performed at a public event will be carried out in accordance with the procedure contained within the Company Operations Manual **must** be obtained from the AOC Chief Pilot.

Pleasure flights

- 6.56 Pleasure Flights for valuable consideration can only be conducted by companies holding an AOC and (with the exception of flights in helicopters) take place only at Government or licensed aerodromes. Initial applications for a temporary aerodrome licence, if required, are to be made to the CAA using form [SRG 2003](#).
- 6.57 Flights conducted under Safety Standards Acknowledgement and Consent (SSAC) or Charity Flights **must not** be conducted during a day when a Flying Display or associated media coverage is organised.
- 6.58 FDDs **must** coordinate Pleasure Flights and **shall** ensure that they do not take place during the Flying Display period itself, unless the prior approval of both the ATS provider and the Flying Display Participants has been obtained. At other times care **should** be taken to ensure integration with other air traffic.
- 6.59 For Pleasure Flights operated from Flying Display sites, passengers **must** be escorted between the Spectator [Area](#) and the aircraft, both before and after each flight, and **shall** remain behind the Crowd Line whilst aircraft are displaying. The escort route **must** be planned to take them safely clear of other aircraft. All personnel associated with the pleasure flying operation **must** remain behind the Crowd Line when aircraft are displaying unless approval from the FDD has been granted and the requirement has been appropriately assessed in the Flying Display Risk

Assessment. Smoking **must not** be permitted in or near to the Aircraft Parking Area.

- 6.60 If helicopters are used for Pleasure Flights they **must** be positioned and routed so as to prevent problems with rotor downwash. In all cases, the site used for passenger loading and unloading **must** be safely clear of the flying area, and approved by the FDD. If the helicopter operating area is not adjacent to the Spectator Area, as could be the case at off-aerodrome events, those parts of the site at which passengers would be expected to assemble before being escorted to the helicopter **should** be fenced off securely. Arrangements **must** also be made to prevent access to the helicopter operating area by third parties.

Pleasure flight escorts

- 6.61 Pleasure Flight escorting **must** be carried out in accordance with the procedures and provisions outlined and contained within the AOC holders Operations Manual. Escorts **must** remain on duty until all Pleasure Flights have finished.

Emergency Services

- 6.62 The FDD **should** ensure the aerodrome operator and EO communicate any degradation in available Emergency Service cover. Flying **may** need to be restricted as a result of any such loss of cover.

Inspection of Flying Displays and Special Events by the CAA

- 6.63 The CAA GA Unit is required to inspect and monitor safety standards at a number of events annually. Written notification will normally be given to the FDD in adequate time stating that a formal inspection of the event will take place. However, the CAA reserves the right to inspect any Flying Display or Special Event without notice.
- 6.64 The CAA Air Traffic Management oversight team **may** exercise its right to inspect facilities, equipment, processes and procedures in cases where a formal Approval against Articles 180, 205 or 206 of the ANO 2016 (as amended) is necessary.

In all cases, CAA inspection staff will endeavour to conduct their duties with minimal impact to the running of the Flying Display.

Chapter 7

Event Organiser (EO) – Guidance and information

The Event Organiser (EO)

- 7.1 This chapter outlines matters of particular relevance to the role of EO. The EO has a broad role in relation to the planning, organisation and wider aspects of the Flying Display.
- 7.2 One person **must** assume overall responsibility as the EO. Responsibility for particular aspects (such as site survey, air traffic services, provision of Emergency Services, liaison with local Safety Advisory Groups (SAG) and conduct of flying activities) **should** only be allocated to people with the relevant experience and, if applicable, licences.

Finding an FDD

- 7.3 It is vital that an EO engages and works with a CAA accredited FDD from the start of the planning process. FDDs are ultimately responsible for the management and safety of a Flying Display and **should** therefore be involved, consulted and aware of any arrangements made that affect it.
- 7.4 The CAA will administer a combined military / civilian [accredited FDD list](#) that will be available to EOs and HoEs. The list will detail an individual's qualification (i.e. FDD accreditation).

Liaison with the Local Authority and Emergency Services

- 7.5 Liaison with the Local Authority, Police and Emergency Services (including [Maritime and Coastguard Agency](#) and [Royal National Lifeboat Institution](#) for offshore display sites) at the start of the planning stage for a Flying Display or Special Event is absolutely vital. Local Authorities and Emergency Services have considerable expertise in planning for large public events and can assist EOs in the planning process. Notification to the local SAG will enable the Local Authorities and Emergency Services

to start initial planning and provide early guidance and support to the EO. However, time is of the essence and contact **should** be made as soon as planning for an event is started. As a guide, the model timescales for contacting Local Authorities, Emergency Services, Coastguards, etc, are:

Event size	Classification	Ideal notice period
Small	Tier 1	2 - 3 months
Medium	Tier 2	4 - 6 months
Large	Tier 3	10+ months

- 7.6 Given the considerable variation of Flying Display activity, both in terms of size and content, it is impossible for this CAP to specify in detail what level of emergency cover **should** be provided. Specific local circumstances, availability of on-site services (particularly at an active airfield), type and numbers of displaying aircraft and the anticipated crowd size will all influence the level of emergency cover required.
- 7.7 Information within the event Emergency / Safety Plan and Flying Display Risk Assessment detail the control measures to be used to mitigate the risks identified. This information is used by the Local Authority and Emergency Services to determine their capability to respond to an incident.
- 7.8 Where SAG meetings are held, attendance by the EO and / or FDD is essential to the Local Authority and Emergency Services understanding of the risks identified at specific events.

The Emergency Plan

- 7.9 The information contained in the Health and Safety Executive (HSE) Event Safety Guide (the [Purple Guide](#)), applies to Flying Displays. Since the EO is responsible for the production of an Emergency Plan, it is recommended that they read the HSE Event Safety Guide prior to writing their Emergency Plan. Suitable and sufficient Risk Assessments **must** be produced and circulated to all contractors and Emergency Services working at the event location or in the adjacent affected areas. These

Risk Assessments **must** contain specific mitigation for dealing with any aviation related hazardous materials which could become an issue following an incident.

- 7.10 An integrated Emergency Plan is an essential pre-requisite for any Article 86 Flying Display and is strongly recommended for Private Flying Displays and Special Events. The size and extent of the Emergency Plan will vary depending on the size and complexity of the event³⁴. The Emergency Plan **must** be agreed by the local SAG and all the services having a role to play within the plan.
- 7.11 EOs **must** remember that an Emergency Plan will require strategies for crowd management and welfare, transport management, fire, first aid, major incident and contingency planning. If the worst does happen, a well-planned event will have a more effective response.
- 7.12 The Emergency Plan **must** include information about how to communicate information on any potential latent hazards that exist within attending aircraft to Emergency Services in the event of an incident.
- 7.13 The size and location of an event can have bearing when deciding who to notify and liaise with within the Local Authorities and Emergency Services. Notifying the local Police and Local Authority planning department can adequately cover a village fete with Flypast. However, for medium and large events, or if in doubt, EOs **should** direct their initial correspondence to the relevant Local Authority Event Planning Department and / or SAG Chair as well as the Chief Constable, Chief Fire Officer and Ambulance Trust Chief Executive Officer. The EO **should** notify each in writing, and, if the event straddles more than one area (e.g. two local authorities), all SAGs **should** be notified.
- 7.14 The EO and / or FDD **should** maintain a record of their engagement with the SAG and / or Local Authority and Emergency Services as appropriate.

³⁴ For example, at a single item Flying Display it may suffice to have a list of contact telephone numbers for the local Emergency Services. At major Flying Displays, a comprehensive written plan will be required specifying the responsibilities of all parties in the event of an incident arising.

Risk Assessment

7.15 Risk assessment is an essential element of the production of any safety plan. Whilst the FDD is responsible for the content of the Flying Display specific content of an event Risk Assessment, it is the EO who is responsible for the event Risk Assessment as a whole. The procedure detailed at Appendix A ought to suit most Flying Display and Special Events needs.

Local Authorities

7.16 Local Authorities have control of the various public services which an EO **may** wish to use. In addition, they need to be aware of the aerial activity which is to take place in order to anticipate any queries or complaints which might arise. Depending on the size of the event this **may** include liaison with local SAG(s). The Event Emergency Plan will be expected to comply with the Local Authority's existing major incident plans and the Civil Contingencies Act 2004.

The Police

7.17 The role of the Police at any public event is:

- a) the protection of life and property
- b) the prevention and detection of crime
- c) the prevention of breaches of the peace
- d) to respond in the case of an immediate threat to life and public safety and co-ordinate the response of the Emergency Services

The Emergency Services **should not** be expected to fill any gaps in event arrangements due to either inadequacies / omissions in the planning process or shortfalls in provisions to be delivered by any other party involved in the organisation, staging or management of the event.

7.18 The likelihood of criminal activity (including terrorist attack) or disorder **should** be incorporated into the event Safety / Emergency Plan and Risk Assessment. Further information on Counter Terrorist Security Advice for EOs can be found on the National Counter Terrorism Security Office

website: <https://www.gov.uk/government/organisations/national-counter-terrorism-security-office>. Police forces have Counter Terrorist security advisors who can be consulted as part of the planning process. Early engagement will ensure that EOs are appropriately briefed about the national threat level and any emerging intelligence or threat relevant to their event.

- 7.19 The Police have no general powers to control or direct traffic at events unless during an emergency situation, therefore, this function **should** be delegated to an accredited Traffic Management Company. Although the Local Authority are responsible for approving the traffic management plan ([Part II Traffic Management Act 2004](#)), its development will involve the EO, the Police and, where appropriate, the [relevant Highways Agency](#) through the SAG.
- 7.20 Some events have an onsite event control where a Police presence **may** be required to deal with policing issues and to co-ordinate incident response. Many of the agencies involved in SAG meetings during the planning stages of an event will be the same as those called to respond to a major incident through strategic and tactical co-ordination arrangements.
- 7.21 In the event of a fatal accident or death on site, the Police act as Coroner's officers and, as such, have statutory duties which include securing and preserving evidence at the scene (including testimonies in the form of written statements and recovery of any video / photographic evidence). The Police will conduct an investigation in conjunction with the relevant Air Accident Investigation [Branch](#).

Fire and Rescue Services

- 7.22 Adequate facilities **must** be available on site to respond to any fire or rescue emergency. Aerodromes might have dedicated trained staff available, however, the degree to which these **may** need to be supplemented **should** be identified through the Risk Assessment.

- 7.23 EOs **should** ensure that the Fire Service for the area is notified of an event, even if there appears to be adequate on site resources.
- 7.24 If flying is to be conducted over water then the appropriate Emergency Services, namely, the Maritime and Coastguard Agency and / or the Royal National Lifeboat Institution, **should** be informed.

Appointment of officials

- 7.25 The EO **must** appoint experienced staff to supervise the parking of aircraft and cars, to operate any public address system and to control messengers and other staff. Sufficient marshals **must** be available to control members of the public, to ensure that on and off site emergency vehicle access is kept clear, to be available in the case of emergency and to prevent public access beyond the Crowd Line.
- 7.26 At displays with more than 6 items, only personnel suitably trained and experienced in flight line ground handling of aircraft **shall** be used in the aircraft movement area. For Car Parking, the services of one of the organisations that specialise in the arrangement and management of Car Parks might be worth considering. All officials **must** be thoroughly briefed in the duties expected of them and provided with some means of identification, such as arm-bands.
- 7.27 Air Cadets and other youth organisations may be used as marshals on the strict basis that they are well briefed and supervised by the relevant organisations adult staff.

Local landowners

- 7.28 The CAA strongly recommend that EOs engage and work with local landowners early on in the initial planning stage of any event in an attempt to accommodate and resolve any potential issues or concerns held. Early engagement, good communication and patient diplomatic liaison often pays dividends in helping to build good relationships preventing the escalation of any potentially harmful and unnecessary conflict.

Medical

- 7.29 Medical provision is essential for any event. Notification of an event **should** be directed to the local National Health Service ([NHS](#)) Trust and the Ambulance Service.
- 7.30 A suitable facility in an accessible location **should** be made available and equipped as a first-aid and casualty reception centre. Local branches of the [Red Cross](#) and [St John Ambulance](#) can usually provide first-aid teams and ambulances. These facilities **should** be suitably marked and located within the Spectator Area, but with access to the Display Area.

Chapter 8

Flying Display Director (FDD) – Requirements and information

General

- 8.1 The FDD is required by law to have a Permission from the CAA to act as FDD for an Article 86 Flying Display³⁵.
- 8.2 FDDs are required to be accredited to at least the same tier as that of the event. Details of FDD accreditation can be found at Appendix C.
- 8.3 It is imperative that FDDs manage their workload appropriately by not accepting more responsibility than that required of them. Prior to the event, their focus **should** be on the safe and comprehensive organisation of the Flying Display. On the day of the Flying Display, their focus **should** be on the management of the operational aspects of the display, making sure that the display is run safely and in compliance with the provisions of this CAP. An important aspect of this role is the delegation of duties to suitable personnel to allow the FDD to maintain the 'bigger picture'. This will help the FDD retain overall awareness and aid decision making. Allied to this, FDDs **should**, where possible, avoid unnecessary involvement with EO tasks and responsibilities.
- 8.4 The FDD **must** take an active role in every aspect of the Flying Display including selection of Display Items, display timings, pro-active Display Item deconfliction and pre-event briefings with on and off site Emergency Services where appropriate.
- 8.5 At displays of 7 items or more, the nominated FDD **must not** undertake any duties other than the role of FDD.

³⁵ A FDD is also required for Private Flying Displays.

- 8.6 FDDs who are also EOs for a particular event **should** read the contents of Chapter 7 - Event Organiser (EO) – Guidance and Information.

Display Area

- 8.7 The FDD **shall** be responsible for designating a Display Area. Details of structures occupied by non-essential personnel and any anticipated areas of Secondary Spectators within the Display Area **shall** be annotated on a map / [satellite imagery](#) which is available to participants.

Risk Assessment and emergency planning

- 8.8 The FDD is responsible for the production of the Flying Display aspect of any event Risk Assessment and **shall** assume overall responsibility for that content³⁶. The FDD **should** work closely with the EO in this respect, if not carrying out both roles themselves. The procedure and information contained within Appendix A contains guidance for consideration in the production of the Risk Assessment. Further relevant useful information can also be found in the Health and Safety Executive (HSE) Event Safety Guide, 'the [Purple Guide](#)'.
- 8.9 At many events, particularly airfield sites, the congregation of Secondary Spectators outside of the Airfield Boundary and / or third parties, **may** give organisers cause for concern. Neither the Police nor the Local Authority might have the power to remove such people. The FDD **should** endeavour to anticipate this during the planning process and take necessary steps to reduce the likelihood of this occurring where possible. Blocking the view from obvious vantage points is one method. Consideration **should** also be given to notifying landowners (or if over water, pleasure boat owners) of the risks of allowing Spectators to watch the display / event from their land / vessel. Landowners / owners **should** be advised that they have a legal responsibility to protect the public from obvious and anticipated risks at public events and, in the event of an accident, that they could be held liable for injuries to Spectators on their

³⁶ The FDD **should** be competent in conducting risk management. Therefore, if any FDD feels that they are lacking in this area, the CAA strongly recommends they undertake appropriate risk management training in order that they can competently fulfil their responsibilities as an FDD.

property. It is advised that professional legal advice on such notification is taken prior to action.

Maritime Exclusion Zones

- 8.10 A Maritime Exclusion Zone (MEZ) **should** be used at over-water display venues in an attempt to limit the amount of marine traffic, and therefore Secondary Spectators and third parties, under the Display Area. MEZs that are in close proximity to rivers, estuaries and harbours **may** be legally enforceable but those in open water are likely to be advisory only and therefore rely on the cooperation of local water users. Early consultation with the local Maritime and Coastguard Agency representatives and harbourmasters will help establish what is possible at a particular display venue. It **may** be necessary to allow vessels access to the MEZ at certain times to access a harbour and so this, as well as high and low tide times, could have a significant effect on proposed Flying Display timings. A MEZ **should** ideally be policed by event safety vessels to ensure that it is not infringed prior to and during display times.
- 8.11 Consideration **should** be given to the criteria used to halt a display if the Display Area becomes crowded with marine craft. This detail **should** be included in the Flying Display Risk Assessment.

Danger areas

- 8.12 If planning an event in or close to a 'Danger Area', consideration **should** be given to contacting the controlling authority to see if it is possible to co-ordinate the use of it's airspace. Details of controlling authorities can be found in the Enroute Information section of UK AIP.

Deputy FDDs (DFDD)

- 8.13 To help safeguard against last minute eventualities, particularly for larger Flying Displays, it is recommended that at the planning stage consideration is given to the risks associated with the primary FDD becoming unavailable at short notice and the possible consequences this could have. One solution is the nomination of a suitably accredited

DFDD. Such a deputy **shall** be familiar with all aspects of the planning of the specific Flying Display and be aware of, and prepared for, any particular duties expected of them on the day of the event.

- 8.14 When it is considered necessary to have a DFDD, details of the nominated person **shall** be entered on the Flying Display application form.

Document checks and insurance

- 8.15 Prior to the Flying Display, FDDs are responsible for satisfying themselves that all pilot, aircraft and insurance documentation is current, valid, applicable and appropriate. All participating civilian pilots **must** hold a current licence with a current class or type rating, or, where no type rating exists, an Aircraft Type Rating Exemption (ATRE), which entitles them to fly the type of aircraft to be displayed.
- 8.16 A certified declaration as contained at [SRG1327](#) is considered to be acceptable documentation for civilian pilots to provide to the FDD. However, FDDs have the right to check all documentation at their discretion. Participating pilots **must** be prepared to produce copies of all the documents referred to in [SRG1327](#) if required for inspection. It is the Display Pilot's responsibility to ensure that the information submitted about themselves and their aircraft is not false, inaccurate or misleading and that any flight is undertaken with valid documentation.
- 8.17 Although details of a pilot's DA are included in the [SRG1327](#) declaration, FDDs **must** check the Display Authorisation document for each Display Pilot to ensure its validity³⁷, applicability and minimum heights. For restrictions relating to civilian registered ex-military jets refer to CAA Safety Notice [SN-2018/001](#).
- 8.18 Exemptions from the need to hold a DA **may** exceptionally be issued, but only for a specific display approved by the [CAA GA Unit](#). No deviation from the agreed routine is permitted, except where this is justified by safety concerns. This is of particular relevance to Air Operator's

³⁷ DAs are only valid if the pilot holds either an EU medical certificate issued by an Aeromedical Examiner or an ICAO medical certificate that is of an equivalent or higher standard.

Certificate (AOC) operators of large transport aircraft where the display Permission will generally be for a simple demonstration or Flypast.

- 8.19 For military participants it can be assumed that the required documents contained in [SRG1327](#) are in order once the booking has been confirmed by the MOD.

Military participation

- 8.20 Where military participants are to conduct a Role Demonstration or a Flypast (Mil) at a Flying Display, the CAA considers the military Aviation Duty Holder (ADH) or Accountable Manager (Military Flying)'s (AM(MF)) approval of manoeuvres appropriate for the pilot to conduct those activities.
- 8.21 As military Participants are not required to submit an [SRG1327](#) certificate, the FDD is to obtain details of the Display Routine as authorised in their PDA for reference during planning and display monitoring.
- 8.22 For further guidance related to military participation at a Flying Display (both UK and foreign military), refer to chapter 1 of this document and [Regulatory Article 2335](#).
- 8.23 FDDs **must** ensure that military participants are aware of any CAA Permission that is in place at the same location and on the same day as any military involvement. This particularly applies to smaller events.

Foreign civilian participation

- 8.24 For further guidance related to foreign civilian participation refer to chapter 1 of this document.

Tyro DA (TDA) participation

- 8.25 To help create an opportunity for newly qualified Display Pilots to gain experience and exposure within the Flying Display community, the CAA allows FDDs to offer up to 2 Display Items per Flying Display to TDAs without incurring any extra charge if those additional item(s) move their display into a higher price band. It follows therefore that the maximum

number of Display Items in each price band need to be occupied before any free TDA Display Items become available. It is permissible for a single Display Item to contain more than one TDA provided they are a constituted display formation or act. However, Display Items containing a combination of established DAs and TDAs do not qualify.

- 8.26 The maximum number of TDA Display Items permitted at a Flying Display are:

Flying Display Price Band	Number of TDA display items permitted
1 – 3 display items	0
4 – 6 display items	1
7 - 12 display items	2
13 - 18 display items	2
19 – 24 display items	2

- 8.27 When [applying](#) for a Flying Display Permission, FDDs **should not** include TDAs in the Participating Display Aircraft count on the application form. It is essential though that any TDA display items are shown on the [Aircraft Display Item Schedule](#) and included in the totals at the bottom of the form. The initials 'TDA' **must** also be entered next to the pilot's name on the schedule. An email **must** be sent to the [CAA GA Unit](#) to notify the intention to include TDAs in a Flying Display and **must** include the Flying Display application number (ADO XXX), pilot's name and type of aircraft to be displayed.
- 8.28 The FDD **should** check the Display Pilot's TDA letter and log for validity (expiry date and number of logged TDA displays) and, to avoid inadvertent charges, gain confirmation from the Display Pilot that the available number of free TDA displays will not be exceeded (therefore invalidating the qualifying requirements) before participation in the planned Flying Display.

- 8.29 The FDD **must** comment on the TDA on the joint CAA / MAA 'Flying Display Director Post Display Feedback Form' [SRG1305 / Form 4](#), if any TDA participation was planned regardless of whether or not the TDA performed the display.

Parachute, paraglider, para-motors, hang-glider and foot-launched aircraft participation

- 8.30 FDDs **should** consider programming events in such a manner that potential conflicts between aircraft and the subject Display Items are minimised.
- 8.31 The content and order of the Flying Display programme **should** take into account the type of display act that is before and after participation by any of these display items, with particular consideration to separation distances and times required for residual vortices from other aircraft to dissipate, particularly in light (or nil) wind conditions.
- 8.32 Aircraft landing or taking off, other aircraft with engines running and propellers or rotors turning constitute a hazard to these display items. In order to minimise the risks FDDs **shall** ensure that the following procedures are followed:
- a) All pilots **shall** be briefed on the procedures to be followed during any display involving these Display Items.
 - b) Propellers, jet engines or helicopter rotors **must not** be turning closer than 250 metres from any area intended for landing / manoeuvring by these Display Items during the period that are operating.
 - c) Pilots of aircraft outside a radius of 250 metres (1000 metres in the case of Pleasure Flights), both airborne and on the ground, **should** remain aware of the progress of any display being performed by

these Display Items, and, if on the ground, be prepared to stop engines or rotors if a conflict becomes apparent.

Flying Control Committees (FCC)

- 8.33 Flying Displays consisting of 7 Display Items or more **must** have an FCC, details of which should be on the application. Additionally, the CAA may, following review of the complexity of an application, require an FCC for Flying Displays with fewer than 7 Display Items.
- 8.34 In exceptional circumstances, the FDD may apply for an exemption from the requirement for an FCC by sending suitable justification to the CAA GA Unit.
- 8.35 A FCC **shall** be appointed by the FDD who **shall** issue the FCC with appropriate Terms of Reference.
- 8.36 With large FCCs nomination of a Chairman (CFCC) to oversee the allocation of tasks within the FCC can be beneficial and relieve the FDD of administrative tasks. If appropriately accredited, the CFCC **may** also be a suitable person to act in the role of DFDD.
- 8.37 The roles of the FCC are:

- a) To assist the FDD in the safe execution of the Flying Display
- b) To assist the FDD in monitoring the standard and Flying Display related discipline of Participants
- c) Assist the FDD in the validation of any display Participants, if required
- d) To provide the FDD with specialist knowledge regarding specific display items
- e) To provide the FDD with a specialist opinion in case of any regulatory infringements
- f) To advise the FDD on restrictions or additional limitations if required
- g) To monitor the conduct of all display participants for regulatory compliance
- h) To intervene or stop, on the grounds of safety, any display Participant or, in extreme cases where the FDD cannot be consulted, the whole Flying Display
- i) To assist the FDD in other duties as directed and agreed

8.38 The FCC **should** be available throughout the period of the Flying Display.

Flying Display Director further considerations

8.39 It is essential that FDDs and FCCs are located where the entire Display Area is clearly visible and displaying aircraft can be monitored for safety and compliance with limitations. It **may** be necessary to split the location of FCC members to cover the whole display site. In all cases FCC members **must** have robust and immediate means of communicating with the FDD.

8.40 The Display Area **must** be observed for pop-up gatherings of Secondary Spectators, or other members of the public, and, if observed, appropriate action taken.

8.41 During the Flying Display, the FDD, supported by FCC members and assisted by any DAEs present, **must** monitor the safety of the performances with reference to conditions contained on the Permission documents and the information that they have about the intended manoeuvres / routine / pilot's DA / PDA minima and any restrictions.

- 8.42 To enable effective monitoring, the FDD **should** prepare a spreadsheet containing pertinent minima for each Display Item and distribute a copy to each member of the FCC for easy reference during a display³⁸.
- 8.43 It is vital that the FDD has adequate means of communications with all appropriate agencies and Flying Display Participants throughout the Flying Display. In the event that the FDD is sited away from the ATS unit, a robust communications link **must** be established to enable two-way communications in the event of an emergency. In emergency situations mobile telephone networks may become overloaded preventing effective communication, therefore it is not appropriate to rely solely on mobile telephones for essential emergency communication unless there is no other viable alternative.

Minimum heights and visibility

- 8.44 FDDs will have the best understanding of all operational factors and hazards relevant to their event and as such **may** set more restrictive height and visibility limits than those contained in this CAP or on the relevant Permission or pilot's DA / PDA. However, when considering setting more restrictive limits, FDDs should take into account how this might affect display manoeuvres / routines and whether any adjustment to the limits may inadvertently create more risk, particularly the risk of Human Factor errors. Any additional limits must be communicated to display pilots as early as possible.
- 8.45 During the display, although difficult to monitor from the ground, the FDD / FCC **must** monitor the aircraft manoeuvres and if the required parameters look likely to not be met, the display **must** be halted with a STOP call.
- a) Pilots with a higher minimum aerobatic height than flypast height are (having achieved the necessary entry parameters) permitted to fly a straight climb from Flypast height into an Aerobatic Manoeuvre. Similarly, they can, once certain of achieving a recovery no lower

³⁸ The FDD **should** also have a list of appropriate minima to hand even if the Flying Display does not require an FCC.

than their minimum aerobatic height, ease down to Flypast height if the next manoeuvre is non-aerobatic. Where one Aerobatic Manoeuvre is linked directly to another, the aircraft **must** remain above minimum aerobatic height throughout the transition

- i) A straight climb from minimum Flypast height into an Aerobatic Manoeuvre **shall** be flown at no more than 30 degrees pitch angle until passing minimum aerobatic height
 - ii) When easing down to Flypast height after an aerobatic recovery the aircraft **shall** remain straight and at no more than 30 degrees pitch angle³⁹. It is important that FDD / FCC monitor visually all aerobatic recoveries to confirm that linked aerobatic manoeuvres are flown to the aerobatic minima rather than Flypast minima
- b) When aircraft blend between aerobatic and Flypast minima as described above, the FDD / FCC **should** see a definite reduction in aircraft pitch rate while the aircraft is still above minimum aerobatic height as the pilot relaxes and enters a gentle descent to the lower Flypast height. If the aircraft is pitching hard throughout the final portion of the recovery and only achieves level at Flypast height, the pilot has clearly not met the requirement to be able to level off at aerobatic minima.

STOP Calls, Standard Warning Calls and safety breach reporting

8.46 In order to communicate any concerns to the displaying pilot, the standard calls outlined in Chapter 6 **shall** be used and the appropriate standard response expected.

Airborne Flying Display Directors (AFDD)

8.47 Provided a pilot holds a DA, and the appropriate behavioural and attitudinal assessment has been completed satisfactorily, Display Pilots **may** act as AFDDs at Flying Displays. In this case a suitable person

³⁹ In practice, the descent will be shallow and flown at much less than 30 degrees pitch angle.

responsible for contacting Emergency Services in the event of an incident **must** be present on the ground and **must** be clearly nominated and agreed in advance. The AFDD **must** brief the responsible person and **should** provide them with a completed SRG 1330 which contains the information required to ensure an expeditious response to any incident involving their aircraft. Details of this person **must** be entered on the on-line Flying Display or Special Event application form.

- 8.48 Pilots **may** act as AFDDs at events consisting of up to 3 single Display Items per day at the location of the event. A single application **shall** be submitted specifying one AFDD as the person responsible for correspondence with the CAA and the subsequent briefing and display co-ordination with the other participating AFDDs. A single Flying Display Risk Assessment is to be produced with the combined involvement of each AFDD (including a signed declaration from each) and submitted with the application. Each AFDD will be named on the Permission. However, on review of any application, the CAA **may** require a ground based FDD to be in place.
- 8.49 In the event that more than one Display Item is planned, only one item **shall** be airborne in the vicinity of the Display Area at any one time. Items **should** be deconflicted by time and / or space to reduce the possibility of mid-air collision.
- 8.50 It is vital that Display Pilots acting as AFDDs are fully aware, and understand, the extent of the responsibility being accepted when accepting and agreeing to act in this role.
- 8.51 AFDDs **must** ensure that they are deconflicted from any other aerial activity in the vicinity of the display location prior to displaying⁴⁰.
- 8.52 The opportunity to formally accredit as an AFDD will become available from mid March 2020. Registration for the online course⁴¹ will be available

⁴⁰ Such as military aircraft, AOC helicopter rides, role demonstrations by the Emergency Services, model aircraft / drone flying, etc.

⁴¹ A SKYWISE message will be issued to promulgate the availability of the AFDD on line course

from mid-March to 31 May 2020 and DA holders are **strongly** encouraged to complete the course within that timeframe. From 2021 the course will be **mandatory** for all DA holders wishing to conduct an AFDD role.

8.53 The course will cover a number of topics specific to display flying as well as the planning, organisation and management of Flying Displays and will include broad detail of the following:

- a) Regulatory compliance
- b) Planning and organising safe Flying Displays
- c) Flying Display Risk Assessment management and review
- d) Obtaining necessary Permissions and planning display in accordance with regulatory rules
- e) Air Traffic Service provision and radio communication at displays
- f) Maintaining flying discipline
- g) Briefing and debriefing of participating aircrew
- h) MOR and post event reporting
- i) Understanding of human factor influences on the safety of Flying Displays and how to address them

8.54 **Validity.** AFDD accreditation will remain valid for a period of 3 years subject to ongoing fitness for the role. Behavioural and attitudinal fitness assessments are valid for 1 year. A completed [SRG 1303B](#) is to be submitted each year prior to, or alongside, the first Flying Display application made by the individual AFDD.

8.55 **Currency.** To maintain currency an individual must act as AFDD at least once every year⁴².

8.56 Successful completion of a ground based FDD Accreditation Course will automatically reset the status of the 3-year AFDD accreditation validity.

Post display feedback

8.57 FDDs / AFDDs **must** submit a Post Display Feedback Report using the joint CAA / MAA 'Flying Display Director Post Display Feedback Form'

⁴² AFDD currency cannot be used to maintain any ground FDD currency

[SRG1305/Form 4](#) within seven days of the conclusion of the Flying Display. The report contains details of the Display Items that performed on each day of the display, what went well, any lapses and breaches from the required standards, any Warning, Terminate or STOP calls made and any lessons learned. In addition to the pilot's name and aircraft type, when reporting Warning calls, it is important to include details of the trigger and subsequent actions, and any debriefs undertaken. The FDD **should** use any information provided by the FCC, performing pilots and any DAEs in attendance in writing the report.

- 8.58 **RA(T) / airspace infringements.** It is vital that every incident is reported, including infringements that nearly happened but were stopped by ATCO / FISO / FDD. In addition to reporting on the [SRG1305 / Form 4](#), a [CAA Mandatory Occurrence Report](#) (MOR) **should** be submitted which will allow the CAA to investigate and understand the extent of the problem.
- 8.59 It **should** be noted that the submission of a completed [SRG1305 / Form 4](#), within the prescribed timescale, is a condition related to the relevant Permission and as such, if not complied with, an FDD would be in breach of the Permission. Further Permissions to such an FDD will only be permitted once all previous Flying Display Director Post-Display Feedback Forms have been received.
- 8.60 The CAA / [MAA](#) uses the intelligence gathered from these reports to better understand the risks associated with Flying Displays, assist DAEs in monitoring and evaluating standards, feedback lessons learnt to the Flying Display community through briefings and seminars, identify opportunities to improve Flying Display safety and inform the annual review of CAP 403.

Reporting of occurrences and incidents

- 8.61 In addition to post-event feedback, FDDs are reminded of the importance of reporting safety related events which endanger or which, if not corrected or addressed, could endanger an aircraft, its occupants or any

other person. FDDs **should** report any events that fall into this category through the CAA Mandatory Occurrence Reporting ([MOR](#)) process.

- 8.62 FDDs are also encouraged to report any incidents or examples of errors involving human factors that occur during a display to [CHIRP](#) who have a dedicated Flying Display reporting stream designed to promulgate to the wider community any lessons learned that could be of benefit to others.
- 8.63 Both of these reporting schemes are confidential and any follow up, or material published, is de-identified to protect the reporter.

Action in the event of an aircraft accident

- 8.64 The DfT Air Accidents Investigation Branch ([AAIB](#)) **must** be informed of any [aircraft accident or serious incident](#) by the quickest means of communication available. The AAIB 24 hour reporting line number is 01252 512299. The Police **must also be notified**.
- 8.65 A accident or serious incident involving a military aircraft at any Flying Display must be reported immediately to the MOD Deputy Chief of the Defence Staff Duty Officer via telephone on 030 6788 8938. Further details may be available in the military Operation Order, if one has been issued.

Summary of FDD responsibilities

- 8.66 The FDD is responsible for:
- a) The conduct of the activity carried out pursuant to a Permission issued by the CAA for the purpose of carrying out a Flying Display
 - b) The Flying Display component of the event Risk Assessment
 - c) Designing a Display Area
 - d) Ensuring their Flying Display is safely organised and in compliance with the provisions of this CAP
 - e) Ensuring that the Local Authority Safety Advisory Group (SAG) are involved in the planning from the earliest opportunity possible.
 - f) Satisfying oneself that all pilot and aircraft documentation is current, valid, applicable and appropriate

- g) The coordination, control⁴³ and safety of all flying activity
- h) Monitoring flying discipline during a Flying Display
- i) The briefing (including the production of the display pilot's written brief) and debriefing of participating aircrew
- j) The control of the Flying Display programme and cancellation or modification to the programme in the case of adverse weather or other conditions that directly affect the Flying Display
- k) The appointment and management of a FCC (if required)
- l) Ensuring appropriate arrangements for the Flying Display are in place, including procedures for incident management
- m) Submitting post event feedback (and occurrence reporting if required)
- n) Having an in depth working knowledge of the contents of this CAP.

⁴³ Where an ATS is being provided by a licenced ATCO, the responsibility for the control of display aircraft rests with the controller. FDDs and ATCOs must understand the boundaries of their responsibilities and mutually brief prior to the event to ensure there is no ambiguity and to agree any bespoke procedures including responsibilities for warning and STOP calls.

Chapter 9

Air Traffic Services – requirements and information

General

- 9.1 This section provides guidance on the requirements for the provision of an Air Traffic Service (ATS), Air Ground Communication Service or Radio Communication Service at a Flying Display or Special Event.
- 9.2 EOs **should** ensure that the type of service they intend to provide is appropriate for their event and that notification periods outlined in both this Chapter, and Chapter 3, are complied with. The CAA **may**, in the interests of safety, direct the person in charge of any aerodrome (other than a Government aerodrome) to provide an Air Traffic Control Service, a Flight Information Service or an Air / Ground Communication Service as considered appropriate.
- 9.3 As a general guide, if an event is likely to generate more than 100 movements **per day**, proposals **should** be discussed with the appropriate Principal Inspector (ATM). These discussions **must** be initiated in order to allow at least 60 days from submission of the application to the date of the event. If any doubt exists as to the need to provide an Air Traffic Control Service, the organiser **should** contact the appropriate Principal Inspector (ATM) for advice.

Air Traffic Control Service

- 9.4 The requirement to provide an Air Traffic Control Service depends on various factors, some of which are listed below:
- a) The number of aircraft expected to attend, the arrival / departure 'time window' available for these aircraft and the movement rate generated by such

- b) The complexity of the flying programme e.g. is the event fixed-wing aircraft only or a mix of rotary and fixed-wing aircraft? Are a wide variety of aircraft types expected? Is it intended to operate cross runways and / or include twilight operations?
 - c) The need to co-ordinate the activity with other ATS units in the area
- 9.5 Established ATC Units intending to facilitate a Flying Display or Special Event that involves any new or significant changes to established ATM arrangements at their units **should** notify their ATS regional office.
- 9.6 Approval for a Temporary Air Traffic Control Unit is required under Part 7 of the ANO. Article 205 Approval (Air Traffic Service Equipment) and Article 206 Approval (Air Traffic Service Equipment Records) are included in this requirement. It is essential that details of the radio and recording equipment to be used are submitted a minimum of 60 days before the date of the event.
- 9.7 If it is intended to establish a Temporary Air Traffic Control Unit at an event, it is essential that organisers / operators refer to CAA CAP 670 ATS Safety Requirements, which contains comprehensive information and requirements for the establishment of such a unit.
- 9.8 Information on the licensing of controllers for the purpose of establishing a Temporary Air Traffic Control Service is available in CAP 1251.
- 9.9 The provider of an Air Traffic Control Service **must** be nominated and he is required to apply to the appropriate CAA ATM Regional Office for approval by a minimum of 60 days in advance of the event. Applicants for the provision of a temporary Air Traffic Control Service **shall** complete form OfW586a (Aeronautical radio ground station licence application form) and submit to Ofcom, FAO Spectrum Licensing (Aeronautical). A copy of the proposed Manual of Air Traffic Services Part 2 (MATS Part 2) **shall** be submitted to the CAA ATM Regional Office as soon as possible but no later than 60 days before the event. Guidance on the format of the MATS Part 2 is provided in CAP 670.

9.10 Questions relating to air traffic personnel requirements, provision of a Visual Control Room and the procedures relating to the inspection and approval of any facility are to be addressed to the appropriate Principal Inspector (ATM).

9.11 The addresses of the CAA ATM regional offices are:

Principal Inspector (ATM)
Safety and Airspace Regulation Group
Aviation House
Beehive Ringroad
Crawley
West Sussex
RH6 0YR
Telephone: 01293 573692 or 01293 573697
Email: ats.southern.regional.office@caa.co.uk

Principal Inspector (ATM)
ATM Northern Regional Office
First Floor
Kings Park House
Laurelhill Business Park
Stirling
FK7 9JQ
Telephone: 01786 457418
Email: ats.northern.regional.office@caa.co.uk

9.12 Further information applicable to the conduct of Special Events and ATC licensing requirements can be obtained from the following documents:

- a) [CAP 670](#) ATS Safety Requirements
- b) [CAP1251](#) Air Traffic Controllers - Licensing
- c) [CAP 793](#) Safe Operating Practices at Unlicensed Aerodromes
- d) [Aeronautical Information Circulars](#)
- e) [CAP 393](#) Air Navigation Order

Flight Information Service

9.13 EOs who wish to provide a Flight Information Service (FIS) at a temporary site, or at an established site not normally providing FIS, are required to apply to the appropriate CAA ATM Regional Office and submit a

completed form [OfW586a](#) to Ofcom (FAO Spectrum Licensing (Aeronautical)) at least 60 days prior to the event.

- 9.14 Temporary FIS **must** be provided in accordance with [CAP 797](#) and [CAP 1032](#).
- 9.15 Established FIS Units intending to facilitate a Flying Display or Special Event that involves any new or significant changes to established ATM arrangements at their units **should** notify their ATM regional office.
- 9.16 All relevant systems used in the provision of an ATS will require approval in accordance with the requirements of the [ANO](#).
- 9.17 Procedures for safe and efficient management of flights **shall** be collated and submitted a minimum of 60 days before the event. Guidance for the format of the Local Instructions is detailed in [CAP 797](#) Flight Information Service Officer Manual.
- 9.18 Organisers **should** refer to the following documents which are also available on the CAA website:
- a) [CAP 1032](#) Aerodrome Flight Information Service Officer Licensing
 - b) [CAP 797](#) Flight Information Service Officer Manual
 - c) [CAP 774](#) UK Flight Information Services
 - d) [CAP 413](#) Radiotelephony Manual
- 9.19 Further guidance can be obtained from the appropriate ATM Regional Office and an application form [OfW586a](#) may be obtained from the [Ofcom web site](#).

Air Ground Communication Service (AGCS)

- 9.20 Many temporary events are supported by the provision of an Air Ground Communication Service (AGCS). FDDs **must** ensure that they have obtained an Article 205 approval and that personnel providing the AGCS possess a Radio Operator's Certificate of Competence (ROCC) (CA 1308). The holder of the Wireless Telegraphy Act (WTA) Licence is responsible for ensuring that all individuals using the radio are competent

in both the operation of the equipment and local procedures and **must** sign the certificate of competence to confirm this. FDDs **should** refer to:

- a) [CAP 452](#) The Aeronautical Radio Station Operator's Guide; and
- b) [CAP 413](#) Radiotelephony Manual

9.21 Applications for AGCS should be made to Ofcom using form [OfW586a](#).

Flying Display operational communications

9.22 Some events require communication for synchronisation or intervention purposes only. Typically, [Operational Control Communications](#) (OPC) assignments are used for synchronising single aircraft movements with music or other ground activities. Such assignments can also be made for the purposes of facilitating FDD intervention during a display. The latter use will normally be assigned a 'Judges' callsign. EOs **must** ensure that they have obtained an Article 205 Approval and the [Wireless Telegraphy Act](#) (WTA) Licence. The WTA Licence holder is responsible for ensuring that users of these ground stations use appropriate radio discipline.

9.23 OPC WTA licence applications are to be made to Ofcom using form [OfW586a](#).

Air Traffic Service personnel

9.24 ATCOs, or FISOs intending to provide an ATS at a Special Event or Flying Display based at a temporary site, or a site not normally providing the service intended **must** ensure that they:

- a) Provide a minimum of 30 days' notice to the appropriate Principal Inspector (ATM) specifying the type of service they wish to provide, confirming their licence details and requesting examination dates
- b) Submit completed Forms [SRG 1411b](#) or [SRG 1414](#)
- c) In the case of ATCOs, comply with the relevant requirements of [CAP 1251](#)

Frequency allocation

- 9.25 A request for a frequency is integral to the [ANO](#) approval process. EOs seeking approval are advised to apply as early as possible but not later than 60 days prior to the event. Initiation of the frequency allocation process is achieved through submission of form [OfW586a](#) to Ofcom. For frequencies intended to be used by display aircraft only, it is recommended that the use of “XXXXXX Display” is applied for when proposing the event callsign on form [OfW586a](#).
- 9.26 Change of use of an already allocated and approved radio frequency is not permitted without the further approval of the CAA (ATM Regional Office), and written consent of the existing WTA Licence and [ANO](#) Approval holder (where not the applicant).
- 9.27 EOs should note that frequencies for use in Flying Displays and other Special Events are in extremely short supply, and allocation cannot be guaranteed.

Radio licensing charges

- 9.28 Charges become payable when an application is made for the temporary allocation of a radio frequency, the establishment of a temporary ATCU and the establishment of a temporary FISO unit in support of a Flying Display or Special Event.
- 9.29 Charges for the establishment of a temporary ATCU are detailed in [ORS5 CAA Scheme of Charges](#) (Aerodrome Licensing and EASA Certification and Aerodrome Air Traffic Services Regulation).
- 9.30 Charges for the establishment of a temporary FISO unit are detailed in [ORS5 CAA Scheme of Charges](#) (Personnel Licensing).
- 9.31 Information of Ofcom radio licensing fees, and access to the Ofcom payment portal, can be found on the [Ofcom web site](#). Further advice on individual circumstances can be obtained from spectrum.licensing@ofcom.org.uk.

Chapter 10

Ballooning as part of a Flying Display

Legal requirements

- 10.1 Balloon operators who carry fare paying passengers **must** hold a valid Air Operators Certificate (Balloons) whether tethered or in free flight.
- 10.2 Pilots of free flight balloons are granted an exemption from the requirement to hold a DA by General Exemption [ORS4 No.1278](#).
- 10.3 Pilots of tethered balloons are not required under Article 86 of the [ANO](#) to hold a DA.

General exemption

- 10.4 The General Exemption states that any pilot who is the holder of a Private Pilot's Licence (Balloons and Airships) or a Commercial Pilot's Licence (Balloons) is authorised to act as the pilot of a balloon taking part in a Flying Display without holding a DA.
- 10.5 The General Exemption is available at [ORS4 No.1278](#).

Considerations

- 10.6 The management of any ballooning during the effective times of a Flying Display is the responsibility of the FDD. FDDs can delegate the supervision, planning, organisation and subsequent running of balloon activity to a suitably qualified balloon pilot but the ultimate responsibility for the safe operation lies with the FDD.
- 10.7 Balloons require a large area to lay out and prepare for inflation. This area can be between the Crowd Line and the display axis. The specific requirements for the setup, lay out, inflation, free flight, tethered flight and deflation **should** be discussed with the FDD in advance.

- 10.8 If aircraft are displaying, wake vortices might be generated which could affect the lay out and inflation of the balloons. Consideration by the FDD and or the EO **must** be given to the effects on the Balloon of any form of wind generation.

Chapter 11

Parachuting as part of a Flying Display

Legal requirements

- 11.1 Whilst parachuting itself does not constitute a Display Item requiring an Article 86 Permission, this chapter is included in order to assist EOs and / or FDDs.
- 11.2 Display parachuting can be arranged as an additional attraction at many events including Flying Displays, or as an event in its own right. Display teams **must** be in possession of a valid parachuting Permission as required by Articles 89 and 90 of the [ANO](#). This document is issued by the [CAA GA Unit](#) with a condition that all parachuting operations are conducted in accordance with the relevant provisions of the parachuting Operations Manual currently in force as submitted to the CAA.
- 11.3 Parachute dropping aircraft **must not** execute a low pass after the drop, unless the pilot holds a valid DA, and an Article 86 or SERA.5005 Permission is in place and the flypast has been approved by the FDD.
- 11.4 Aircraft can only be used for parachute dropping if there is information available in the Flight Manual or Flight Manual Supplement relating to parachute dropping for that particular aircraft. The aircraft **must** have approved modifications, if necessary, for the purpose of parachute dropping and **must** be operated in accordance with the Flight Manual or Flight Manual Supplement.
- 11.5 The parachute display team leader is responsible for obtaining any air traffic Permission in principle (e.g. Non-Standard Flights in Controlled Airspace) and for notifying the proposed display to [Airspace Regulation](#), the [British Parachute Association](#) and to the local Police a minimum of 28 days prior to the event.
- 11.6 The parachute display team leader will require to obtain the written Permission of the landowner concerned or their agent.

Liaison and reconnaissance

- 11.7 The management of any parachuting during the effective times of a Flying Display is the responsibility of the FDD. FDDs can delegate the supervision, planning, organisation and subsequent running of a parachute drop to the parachute team leader but the ultimate responsibility for the safe operation lies with the FDD.
- 11.8 An experienced team member will need to visit the proposed landing area in order to plot existing and anticipated hazards. This visit will ideally be made at least six weeks before the proposed display.
- 11.9 The EO, FDD or appropriate representative **should** be present at this visit in order to discuss:
- Weather minima
 - Dimensions of the landing area required by the team
 - Arrangements for crowd control
 - Location of overshoot / undershoot areas, buildings and power lines
 - Locations of Spectator Areas, Car Parks, marquees and other hazards (e.g. cranes used for bungee jumping)
 - First aid
- 11.10 The FDD **must** ensure that the parachute display team leader is informed of any other aviation related activities known to be taking place at the event or nearby (e.g. helicopter Pleasure Flights, tethered balloons, model aircraft).

The Parachute Landing Area (PLA)

- 11.11 Where the designated PLA is on the display side of the Crowd Line, no part of that area **shall** be closer than 15 metres to the Crowd Line.
- 11.12 Where the designated PLA is in an area set aside for Spectators, it **must** be enclosed with rope, tape or fencing and no parachutist **shall** intentionally land closer than 15 metres to any spectator.
- 11.13 The PLA available **must** be a minimum of:

- i) 5000 square metres in area with a minimum width of 50 metres for 'C' and 'D' licence parachutists
- ii) 20000 square metres in area with a minimum width of 100 metres for 'B' licence parachutists

11.14 The PLA **must** be suitably marked and **must** be clearly identifiable by each parachutist from the time he exits the aircraft.

The display

11.15 When the display of parachuting forms part of a Flying Display, the Pilot in Command of the parachute dropping aircraft **must** obtain a briefing from the FDD.

11.16 Aircraft carrying parachutists may overfly the Spectator Area or Car Parks whilst positioning to drop, but not below a minimum height of 1500 feet ASL.

11.17 The parachute display team **shall** provide a ground party at the PLA who **must** be able to communicate with the parachute dropping aircraft by means of signal panels and / or radio.

11.18 Over water displays **must** have a rescue boat in attendance with crew conversant with foot launched aircraft and pilot egress.

11.19 Parachute display team leaders **should** study the additional guidance material for parachuting displays contained within CAP 660 Chapter 4.

11.20 For freefall parachute displays, the minimum height by which parachutists must have their main parachute open is normally 2,500 feet ASL. World Air Sports Federation, Fédération Aéronautique Internationale (FAI), 'C' and 'D' Certificate holders and British Parachute Association 'C' and 'D' licence holders, may delay opening to 1500 feet ASL⁴⁴.

⁴⁴ Static line only: A 1200 feet ASL minimum opening height is permitted.

Chapter 12

Paragliders and Hang-gliders (unpowered) as part of a Flying Display

General

- 12.1 Displays encompassing the operation of paragliders and hang-gliders present unique issues to the EO and / or the FDD. These issues **should** be discussed early in the development of the flying programme.
- 12.2 FDDs **should** consider programming events in such a manner that potential conflicts between other aircraft, paraglider and hang-glider pilots are minimised.

Pilot requirements

- 12.3 Pilots **must** hold a valid recognised paragliding qualification or rating, for example a British Hang-Gliding and Paragliding Association 'Pilot' qualification or the FAI International Para Pro Level 4 qualification.
- 12.4 Pilots **must** hold a valid UK CAA DA with the relevant category included.
- 12.5 Pilots **must** hold a valid radio licence (if required). The use of non-aviation frequency radios is not recommended.
- 12.6 Pilots **must** ensure they have valid 3rd party and public liability insurance, that includes display flying, to an appropriate minimum level of cover.
- 12.7 Pilots will be required to evidence their valid ratings / licences (etc) to the FDD prior to the event by providing a certified declaration as per [SRG1327](#).
- 12.8 The paraglider or hang-glider Display Pilot or team will require the written Permission of the landowner concerned or their agent.

Liaison and reconnaissance

12.9 The FDD, Display Pilot or an experienced team member will need to visit the proposed take off, flying and landing areas in order to plot and record existing and anticipated hazards. This visit **should** ideally be made at least six weeks before the proposed display.

The FDD **must** be present at this visit to discuss:

- a) Weather minima
- b) Dimensions of the landing area required
- c) Arrangements for crowd control
- d) Location of overshoot / undershoot areas, buildings, power lines, roads and Congested Areas
- e) Locations of Spectator Areas, Car Parks, marquees and other hazards (e.g. cranes used for bungee jumping)
- f) First aid

12.10 The FDD **must** ensure that the Display Pilot or team is informed of any other aviation related activities known to be taking place at the event or nearby (e.g. helicopter Pleasure Flights, tethered balloons, model aircraft flying, displaying aircraft).

The Landing Area

12.11 Where the designated landing area is on the display side of the Crowd Line, no part of that area **shall** be closer than 30 metres to the Crowd Line parallel to the approach.

12.12 Where the designated landing approach and landing direction is towards a Crowd Line, no part of the landing area **shall** be closer than 30 metres from the Crowd Line.

12.13 Where the designated landing area is adjacent to an area set aside for Spectators, it **must** be enclosed with rope, tape or fencing. In this case, the minimum designated landing area **shall** have a minimum of 60 metres available for landing into wind with at least 30 metres laterally. In addition

to the 30 metre x 60 metre landing area there **must** be a minimum lateral separation distance of 30 metres in all directions from any Spectators.

- 12.14 No paraglider or hang-glider pilot **shall** overfly any Spectator.
- 12.15 The landing area **must** be clearly identifiable and **must** be fully briefed to each pilot prior to launch.

The display (when the display forms part of a Flying Display)

- 12.16 The paragliding / hang-gliding pilot or display team **must** fly with an emergency (back up) reserve parachute.
- 12.17 The paragliding / hang-gliding pilot or display team **shall** ensure there is a ground party at the landing site who **must** be able to communicate with the launch point or dropping aircraft by means of signal panels and / or radio. The ground party **should** also be able to communicate with the airborne pilots by signal panels or radio.
- 12.18 Over water displays **must** have a rescue boat in attendance with crew conversant with foot launched aircraft and pilot egress.
- 12.19 The display elements **must** be completed and the paraglider / hang-glider **must** be in normal flight to commence the landing approach at a height no lower than 200 feet when over land and 100 feet when over water unless approved otherwise on the pilot's DA.

Post-landing

- 12.20 A specific area suitably clear of obstructions **should** be set aside for the packing up of the equipment. Ideally it **should not** be under the Display Area or be exposed to any downwash, jet blast etc.

Separation Distances

12.21 Minimum Separation Distances for paragliders and hang-gliders are contained in the table below:

Type of aircraft	Type of display	Lateral Separation Distance
Paraglider and Hang-glider (unpowered)	Take-Off / Landing	30 metres
	Flypast	100 metres
	Full Aerobatic*	150 metres

* Full aerobatic flight for these aircraft include, but are not limited to, angles of bank exceeding 60 degrees, spins, loops, inverted flight, figures in which all or part of the aircraft is moving backwards or rotating and manoeuvres in which all or part of the aircraft is collapsed.

12.22 Take-off **may** be commenced from a point no closer than 30 metres from the crowd line provided the take-off run and subsequent climb out continues away from the crowd line to meet and maintain the minimum Separation Distance for the duration of the display.

Down draughts, prop wash and jet blast

12.23 Moving / disturbed airflow, however caused, has a great effect on the control of a paraglider or hang-glider as they are susceptible to air turbulence. Provision **should** be made to reduce the likelihood of rotating propellers, jet blast and turning rotor blades being within the proximity of paragliders so as not to affect them.

Chapter 13

Foot-launched aircraft as part of a Flying Display

General

- 13.1 Flying Displays encompassing the operation of foot-launched aircraft present unique issues to the EO and / or the FDD. They **should** be discussed early on in the flying programme development
- 13.2 Pilots **must** hold a recognised foot-launched aircraft qualification or rating.
- 13.3 Pilots **must** hold a valid UK CAA DA with the relevant category included.
- 13.4 Pilots **must** hold a valid radio licence (if required). The use of non-aviation frequency radios i.e. 'walkie talkies' is not recommended.
- 13.5 Pilots **must** ensure they have valid insurance that includes third party liability and display flying.

Pilot access to the launch area

- 13.6 A specific area suitably clear of obstructions **should** be set aside for the set up and subsequent re-packing of the equipment. Ideally it **should not** be under the Display Area. When selecting a suitable operating area, careful consideration **must** also be given to terrain and obstruction induced turbulence.

Separation distances

- 13.7 Separation Distances for foot-launched aircraft **must** comply with the table in Chapter 5. Take-off **may** be commenced from a point no closer than 30 metres to the crowd line provided the take-off run and subsequent climb out continues away from the crowd line to meet and maintain the minimum Separation Distance for the duration of the display. Otherwise the minimum Separation Distance for take-off and landing **shall** be 50 metres.

Down draughts, prop wash and jet blast

- 13.8 Moving / disturbed airflow, however caused, has a great effect on the control of a foot launched aircraft as they are susceptible to air turbulence. Provision **should** be made to reduce the likelihood of rotating propellers, jet blast and turning rotor blades being within the proximity of the foot-launched aircraft so as not to affect them.

Maximum wind limitations

- 13.9 Take-off and landing has to be made directly into wind, with a maximum wind strength of only 10kts for some foot-launched aircraft.

Chapter 14

Air racing as part of a Flying Display

General

- 14.1 Display flying involves operating aircraft close to their permitted limits while close to the ground without the element of competition. Air Races add an element of competition which can subject aircraft and pilots to greater than normal risks, together with the added psychological pressure of performing to an audience. Accordingly, an un-scripted air race involving multiple aircraft flying the same course in competition introduces a large degree of unpractised manoeuvring that does not fit within the Flying Display environment⁴⁵.
- 14.2 Pre-briefed, 'stage-managed' air racing is permitted at a Flying Display where aircraft fly at pre-determined normal operating speeds, rather than at maximum possible speed.
- 14.3 All pilots **must** hold a minimum of a Tailchase DA. The 'race' must be briefed by the holder of a Tailchase Leader DA. All pilots **must** hold a DA appropriate to any combined manoeuvring planned after the end of the 'race'.
- 14.4 The minimum Separation Distance between aircraft during the 'race', including while overtaking, is 50 metres.
- 14.5 The minimum Separation Distance from the crowd line **must** be in accordance with Chapter 5.
- 14.6 The minimum height (within the authorised Display Area) **must** be the event minima or the individual pilot's permitted minima, whichever is the higher. In addition, for air race scenarios, an absolute minimum of 100 feet AGL / ASL applies.

⁴⁵ This does not exclude competition flying involving single aircraft flying a set course against the clock from being incorporated as part of a Flying Display.

- 14.7 The FDD **should** consider and plan for the variations in speed of the different types involved, as well as any ground handling differences.
- 14.8 The FDD **must** ensure that the 'air race' briefing includes departure order and timing, overtaking, the requirement for aircraft to manoeuvre predictably and to avoid the aircraft ahead especially during and after overtaking, post-race positioning and landings.

Chapter 15

Banner towing as part of a Flying Display

General

- 15.1 Banner towing as part of a Flying Display requires co-ordination between the FDD, the participant and ATS provider as the 'combination' is slow to manoeuvre and susceptible to drift.
- 15.2 Aircraft can only be used for banner towing if there is information available in the Flight Manual or Flight Manual Supplement relating to towing for that particular aircraft. The aircraft **must** have approved modifications if necessary for the purpose of towing and **must** be operated in accordance with the Flight Manual and any applicable Flight Manual Supplements.

DA requirements

- 15.3 The Participant **must** hold a valid UK CAA DA which includes Permission to tow banners.

Separation distances

- 15.4 Pick up gates and drop zones **shall** be no closer than 75 metres from the crowd.
- 15.5 Display passes **must** be such that if the banner falls it **shall** be no closer than 75 metres horizontally from the crowd. Except for pick up and drop passes, the tail of the banner **must not** be lower than 200 feet ASL.

Considerations

- 15.6 Banner towing requires a dedicated area that **should** be set aside for the set up, pick up and dropping of the banner. This area **should** be on open ground with no obstructions particularly on the approach and climb out which is usually into wind.

- 15.7 The combination of towing aircraft and banner **must not** be flown under / over or around by any other aircraft.
- 15.8 Formation **may** be flown with a banner in tow, or with a tow rope attached, provided that any Formation changes are at a safe distance behind the lead aircraft taking into account the possibility of the banner or tow rope separating from the towing aircraft.
- 15.9 When banner towing is conducted outside of an Article 86 Flying Display or SERA Minimum Height and Visual Flight Rules Permission time period, the combination **must** at all times comply with the Rules of the Air Regulations and SERA, with particular attention to Congested Areas, increased density of people and the ability to land clear in the event of an engine failure.

Chapter 16

Twilight and airborne pyrotechnic displays

General

- 16.1 Displays during twilight **should** take account of some additional factors caused by low light levels. Particularly, but not exclusively:
- a) reduced and deceptive visual references
 - b) factors influencing light levels such as cloud and showers
 - c) inadvertent entry into cloud
 - d) a pilot's ability to identify and select a suitable area to force land
- 16.2 The planning by the FDD and the participant **must** identify and reduce the hazards associated with flying in low light conditions (for instance, Display Lines **may** be marked with lights).
- 16.3 Due to the increased risks associated with display in low light levels, all displays during twilight require sufficient inflight visibility to assure visual references can be maintained. The pilot or FDD **may** use higher inflight visibility and height minima having taken into account the terrain, marking / lighting of flightpath and display area, ambient light levels, the loss of visual cues and references, moon phase, calm water and consideration of disorientation due to the 'black hole effect'.
- 16.4 Prior to a twilight display, pilots **must** familiarise themselves with the local topography, emergency landing areas, crowd lines, display lines, and key visual references during daylight.
- 16.5 Pilots **should** plan their manoeuvres to avoid losing sight of key visual references which are required to maintain adequate situational awareness throughout the display.
- 16.6 Manoeuvres that increase the risk of losing situational and spatial awareness with low light levels and limited visual reference points **should** be avoided.

- 16.7 Before a display twilight conditions, pilots **must** plan a strategy such that if they get disorientated and Situational Awareness (SA) is lost, they can regain awareness quickly to ensure a safe outcome.

Considerations include:

- a) visibility, cloud ceiling and wind at flying altitude before display
- b) use of the attitude indicator (if fitted and sufficiently reliable) to update attitude awareness
- c) moving map (GPS) to update position awareness
- d) establishing a minimum 'refuge' height in the vicinity of the display which is safely above local terrain and obstructions for visual flight in conditions of poor light or restricted visibility
- e) key visual references for orientation, including features like the moon, high contrast visual cues on the ground, areas of significant lighting around built up areas.
- f) communication (with formation / tail chase / team members / FDD etc)
- g) modification or termination of display.

Airborne displays using pyrotechnics

- 16.8 As display pilots performing airborne pyrotechnic displays cannot fully assess the fall and safe burn rates of discharged pyros they have left behind, a suitable ground based observer capable of communicating with the pilot **must** be in place to advise⁴⁶.
- 16.9 If the FDD or ground based observer considers that the fall-out is posing a hazard to people or property he **must** call 'Pyros Too Close' or 'Pyros Too Low' or both in order to remove the hazard.
- 16.10 Airborne displays using Pyros **must** take into account the following but not limited to:
- a) Momentary blindness when firing and looking into pyros
 - b) Fall-out from emitting fireworks

⁴⁶ There is no requirement for an observer if only PRT 3 pyros are used.

- c) Increased fire hazards both on the ground and in the air
- 16.11 Pyro devices and projectiles (including dross, embers or remnants) **must not** be released with a trajectory that could result in projectiles landing in spectator areas; consideration **must** be given to release height, wind drift and lateral separation distances increased accordingly.
- 16.12 Both the FDD and pilot(s) **shall** discuss their planned action(s) in the event of an engine failure when the pyrotechnic is burning or still hot. Consideration must be given to the flight path to reach the emergency landing areas.

Pyrotechnic risk classification

- 16.13 For the purpose of determining the risks associated with the use of pyros during Flying Displays, pyros are categorised into 3 Pyro Risk Tiers (PRT)⁴⁷.
- d) PRT 1 – Any pyro with emitted particles that burn for 8 seconds or longer and any pyro with an MPRH \geq 1000 feet. Examples include Aluminium Waterfalls, rocket fireworks, SOLAS parachute flares and shells \geq 75mm
- a) PRT 2 – Any pyro with emitted particles that burn for less than 8 seconds or pyros with a MPRH below 1000 feet. Examples include some waterfalls, Roman Candles, Comets, Mines, cakes and shells $<$ 75mm
- b) PRT 3 – Any pyro with zero dross, “cold burn” proximate pyros, smoke generators and pyros with a ground level MPRH. Examples including fountains, gerbs, flares, flashing bengals, smoke grenades

Minimum Pyrotechnic Release Heights (MPRH)

- 16.14 Pyros **must** be fired or released above a height at which they will have burnt out and cause no risk to public safety by the time they reach the surface. As pyros have varying burn and descent rates, pilots **must** have

⁴⁷ With reference to manufacturers Material Safety Data Sheets (MSDS)

- tested and practiced with the pyros in order to establish the MPRH and PRT. MPRH **must** incorporate a margin for error.
- 16.15 Pyros falling into the PRT 1 and 2 categories **must** be fired or released no lower than the established MPRH.
- 16.16 Pyros falling into the PRT 1 and 2 categories **may** be fired or released from below the established MPRH if:
- a) the pyros are fired or released over water
 - b) the pyros are fired or released over areas specifically risk assessed by the FDD where there is no risk to public safety and a ground based observer / FDD and appropriate fire cover is in place. Details **must** be included in the submitted Flying Display risk assessment.
- 16.17 Pyros falling into the PRT 3 category **may** be fired or released from the higher of either the issued Permission height minimum, that specified in the pilot's DA or any FDD imposed minimum.
- 16.18 Established PRTs and MPRHs for each pyro **must** be declared on form [SRG 1327](#) (Display Pilot's Certified Declaration for submission to the FDD) and agreed in advance with the FDD. Where multiple types of pyro could be used complete details **should be** added to the form as an attachment that includes each pyro's common name, a description of the effect, it's firing duration, PRT, MPRH, position on aircraft and firing choreography, for example:
- a) Outdoor Waterfall, trail of sparks, Duration 60s, PRT 1, MPRH 1200ft, from aircraft wingtips, 2 pyros fired in series at start of the display.
 - b) Roman Candle, multishot of coloured stars, Duration 25s, PRT 2, MPRH 100ft, from aircraft wingtips, 2 separate pyros fired during vertical rolls and loops, see ribbon diagram.
 - c) Smoke Grenade, Duration 45s, PRT3, MPRH Ground level, from skydivers ankle, fired in freefall.

Wind speed and direction of fallout and rate of fall

16.19 Careful consideration **must** be given to where any fallout might reach the surface during normal operation or if a malfunction occurs. A fall out zone must be established for PRT Tier 1 and Tier 2 pyros.

Consideration must be given to the following

- a) Flammability of the Surface of the fall-out zone
- b) PRT, Pyrotechnic type and characteristics of falling embers
- c) Pyrotechnic release heights
- d) Wind at flying heights
- e) Wind at surface
- f) Emergency landing areas and the flight paths required to reach them

Anticipating a pre-ignition and / or failure in the air and on the ground

16.20 Consideration **must** be given to:

- a) The potential for uncommanded ignition or pre-ignition in the air and on the ground, which might cause pyros to ignite out of the planned sequence, momentary blindness and distraction in the air, a fire or smoke hazard on the ground.
- b) Anticipating a forced or early landing before the pyro has extinguished

16.21 Additional pre-display planning is essential to cater for a pyro that might still be alight or hot when the aircraft reaches the ground.

16.22 Routing to and from the venue **should** be carefully planned so as to minimise the risks associated with falling debris.

16.23 Spent pyro canisters might cause runway FOD issues, therefore planning to minimise runway disruption is essential. Consideration should be given to requesting a runway inspection after any landing with spent pyros.

Safety information and special handling details

- 16.24 All pyros require safe and careful handling. Details of specific handling requirements **must** be sent to the FDD and communicated to the Emergency Services prior to the event.
- 16.25 Details of each pyro **should** include who is handling the pyro, the planned storage area prior to preparation and fitting, preparation areas, fitting areas, quantity and position of the pyros on the aircraft.
- 16.26 Each pyro **should** be classified by generic pyro type, UN Number, PRT and MPRH, and Material Safety Data Sheets (MSDS) or a Safety Briefing Summary Sheet⁴⁸ **must** be made available to the FDD.
- 16.27 FDDs **should** discuss the types of pyros that are to be used during the display with the operator and / or pilot to ensure that emissions during the display will be contained within the risk assessed area.
- 16.28 In the event of an inadvertent ground fire that poses a risk to public safety, the FDD **must** terminate the display.
- 16.29 In the event that a ground fire is seen by the pilot, they **should** inform ground personnel (FDD / FCC / ATS) as soon as workload and flight safety permits.
- 16.30 All ground fires **must** be reported on the joint CAA / MAA 'Flying Display Director Post Display Feedback Form' SRG1305 with details.
- 16.31 If a display is stopped due to a ground fire, then an MOR **should** be made with details of why the display was stopped, the type(s) of pyrotechnic, phase of display, minimum altitude being used, location, size and spread of the fire and an account of any injuries.

⁴⁸ When an aircraft carries pyrotechnics across several PRT Tiers, it is recommended the FDD is supplied with a Safety Briefing Summary Sheet to share with the Emergency services.

Chapter 17

Model aircraft and Unmanned Aircraft Systems (UAS) as part of a Flying Display

General

- 17.1 The management of any model aircraft or UAS flying during the effective times of a Flying Display is the responsibility of the FDD. FDDs can delegate the supervision, planning, organisation and subsequent running of a model aircraft or UAS display to a Model Flying Display Director (MFDD)⁴⁹ but the ultimate responsibility for the safe operation lies with the FDD.
- 17.2 Uncontrolled free flight models **must not** be flown during the period of a Flying Display.
- 17.3 The operation of model aircraft and UASs shall be in accordance with the requirements of CAP 658 Model Aircraft: A Guide to Safe Flying and CAP 722 Unmanned Aircraft System Operations in UK Airspace as appropriate.
- 17.4 All applications for model aircraft or UAS Exemptions and Permissions must be made using the application process listed in the UAS webpages of the CAA website www.caa.co.uk/uas. Enquiries should be directed to uavenquiries@caa.co.uk.
- 17.5 Where the designated model aircraft / UAS Display Area is in an area set aside for the Spectators it **shall** be safely enclosed.
- 17.6 Model aircraft and UASs with a mass of more than 20kg are required to hold a CAA Exemption to fly. The Exemption will state the physical characteristics of the aircraft and the name(s) of the pilot(s) allowed to fly it. An Exemption to Test Fly is not valid at a public event including Flying Displays. Pilots are required to hold a British Model Flyers Association

⁴⁹ As defined in [CAP658](#)

(BMFA) Qualification B, or a Large Model Association (LMA) Proficiency, or an equivalent qualification and valid insurance that includes third party liability.

- 17.7 The FDD and the MFDD **should** consider the need to add an additional Separation Distance for models / UASs of exceptional dimensions, weight or performance. Some jet model aircraft are capable of speeds in excess of 200 mph.
- 17.8 The FDD is responsible for ensuring that model aircraft / UAS displays are adequately separated in distance or time from other flying events. Where the model / UAS flying is taking place on the display side of the Crowd Line, there **should** be direct communications between the FDD and the MFDD to ensure that in the event of an aircraft emergency the model / UAS flying can be stopped as quickly as possible.
- 17.9 The MFDD will assist in the planning of the model / UAS Flying Display and is responsible for arranging strict control and use of model / UAS aircraft transmitters and frequencies, the airworthiness of all model aircraft / UASs, the competence and the briefing of their pilots and control of the model / UAS flying area.
- 17.10 An appropriate number of Flight Line Marshalls responsible to the MFDD **must** be appointed at medium to large scale events to directly control the active model flying. At smaller events this role **may** be assumed by the MFDD.

Model aircraft display limitations

- 17.11 The Separation Distances between Spectators and model aircraft / UASs **must** be maintained whether they are flown in a specified area or on the display side of the Crowd Line. Refer to [www.caa.co.uk / CAP658](http://www.caa.co.uk/CAP658).
- 17.12 The Minimum Separation Distance for models / UASs of 7 kg and under is 30 metres. For models / UASs over 7 kg the Minimum Separation Distance is 50 metres, but this distance **may** be reduced to 30 metres for take-off and landing only.

- 17.13 For models / UASs of over 20kg, and all gas turbine powered model aircraft, a greater Minimum Separation Distance of 75 metres is required. This distance **may** be reduced to 30 metres for take-off and landing only.
- 17.14 The FDD and MFDD **should** also consider the need to add an additional separation distance for models and UASs of exceptional dimensions, mass or performance.
- 17.15 The recommended weather limits for model aircraft and UAS flying are a minimum visibility of 500 metres and a maximum wind strength of 25kts.

Full size and model aircraft synchronised displays

- 17.16 Where a Display Item consists of a full size aircraft and a model aircraft or UAS, a number of risk factors **must** be considered. The Display Pilots **must** determine a safe method of flying the routine taking into account the difficulties of ensuring that the required Separation Distance between the two (or more) aircraft and the Spectators is maintained. The judging of full size / model / UAS Separation Distances by the ground based pilot becomes increasingly difficult as the horizontal distance between them and the model aircraft increases.
- 17.17 The Display Pilots will need to fully brief the FDD on the Display Routine including any specific requirements for set up and recovery prior to and after the display.
- 17.18 The model aircraft pilot is not required to hold a DA but **must** hold a BMFA B or a LMA Proficiency, or an equivalent qualification to display at a Flying Display. The Display Pilot **must** have successfully passed an evaluation to upgrade the DA to include 'Display flying with model aircraft'.

Appendix A

Risk Assessment

Flying Display risk management

- A1 At any Flying Display or Special Event there are hazards that might cause harm to people. EOs are accountable for ensuring that their events are managed safely, including the management of the risks created by any display flying that forms part of their event. The FDD is responsible for the Flying Display component of any event risk assessment.
- A2 The risk management procedure that follows ought to suit the needs of most Flying Displays and Special Events. If further advice is required on conducting a Flying Display Risk Assessment or the Risk Assessment process itself, then please contact the [CAA GA Unit](#).

Why is risk management important?

- A3 Displaying aircraft close to the ground and large numbers of people has inherent risks. Risk management should be focussed on identifying the hazards and then minimising the resultant risks so that the probability of an incident is reduced and the consequences of an incident are minimised. A FDD, AFDD or Pilot should understand the hazards associated with the activity being undertaken, in the location it is being carried out, in order to identify the key components in effective risk management.

The risk management process

- A4 Risk management can be challenging and time consuming and it is therefore important that you follow the guidance in this Appendix as a minimum. The risk management process starts with identifying the hazards created by the Flying Display or Special Event and then assessing the risks associated with those hazards in terms of likelihood (what is the likelihood of the risk associated with a hazard happening?)

and severity (if the risk associated with a hazard occurs how bad will it be?). Once the level of risk is identified, appropriate mitigation measures can be implemented to reduce the likelihood or severity⁵⁰ (and accordingly the level of risk) to an acceptable level. The implemented mitigation measures **should** then be monitored to ensure that they have had the desired effect.

- A5 The Health and Safety Executive use the verdict from the Court of Appeal in Edwards vs the National Coal Board in 1949 as a basis for explaining As Low As Reasonably Practicable (ALARP). Making sure a risk has been reduced to ALARP is about weighing the risk against the sacrifice needed to further reduce it. Taking all Reasonably Practicable measures to reduce a risk does not automatically mean the risk is acceptable or tolerable; an FDD or pilot has to judge whether an activity is still appropriate having taken all the Reasonably Practicable measures possible.
- A6 The complexity of the risk management process **should** reflect the scale of the risk created by the display being planned. This applies both in terms of the scale of the event and in terms of the individual hazards that are identified. For example, it would be expected that a large Flying Display with a number of different Display Items / types with a significant number of spectators would identify more hazards (and therefore risk) than a smaller, simpler event where far fewer people and aircraft might be involved. As such, a larger event will require more consideration than a smaller event and the Risk Assessment will differ accordingly.
- A7 Risk Assessments **should** cover all people associated with a Flying Display, including pilots, staff and volunteers and members of the public both inside and outside of the event. In general, the purpose of the Risk Assessment is to determine the risk posed to people and how that risk is mitigated to an acceptable level.

⁵⁰ In most cases, the severity of the outcome is more difficult to reduce than the likelihood of the risk occurring, therefore risk assessors **should** concentrate primarily on reducing the likelihood to reduce the risk to ALARP.

- A8 All Risk Assessments are reliant on both the quality of the information used and the knowledge of the people involved when conducting the assessment. Therefore, it is important to include people with relevant expertise and experience in the risk management process to ensure its accuracy and robustness.
- A9 It follows that the risk management process **must** be undertaken by people who are aware of the risks associated with the activity being assessed, have knowledge of the range of mitigations available to reduce any risk and who can use sound judgement in the preparation of the assessment. The assessor(s) **should** also be aware that in the event of a subsequent accident or incident, the Risk Assessment process might be challenged.
- A10 The risk management process is illustrated below:



Hazard / risk definition

- A11 A hazard is defined as any condition, event, or circumstance which could induce an accident⁵¹.
- A12 A risk is defined as a combination of the likelihood of a hazard occurring and the severity of the accident that could result; e.g. the higher the risk, the more likely the accident will occur and / or the more severe will be the consequence.
- A13 For example, bird activity in or around an aerodrome is a hazard to aircraft operations. One risk associated with this hazard is that a bird strike causes an aircraft engine to fail resulting in the aircraft crashing, harming the pilot and / or the public.
- A14 In general, a hazard exists in the present whereas the risk associated with that hazard is a potential future outcome.

Hazard identification

- A15 Hazard identification is fundamental to effective Flying Display risk management and there are benefits to approaching the task formally. Depending on the size of the display, and the organisation surrounding it, there are many ways of identifying hazards. The following methods might be useful:
- a) **Brainstorming.** Where a safety committee, Flying Control Committee and others involved in the organisation of a display meet to identify possible hazards. Simulation and table top exercises of possible scenarios can be an effective part of the brainstorming process. It **should** be noted that brainstorming sessions need not be limited to Safety Committee and FCC members and can include any interested parties or person thought worthy of inclusion
 - b) **Review of data.** Reviewing data from previous accidents and incidents can provide a useful source of information to assist with hazard identification.

⁵¹ Accident as defined in [CAP 760](#).

- c) **Incident reporting.** Mandatory / voluntary incident reporting schemes (internal and external) can provide information to help guide the hazard identification process.
- d) **Audits.** Internally or externally conducted safety assessments / audits (if available) can illustrate and highlight potential pitfalls that have been identified previously.
- e) **Safety information.** Safety information from external sources; e.g. similar organisations, media, AAIB, CAA, HSE, etc also provide useful data that can help with hazard identification.
- f) **Generic hazard checklists.** These can be found on the internet and through organisations such as the HSE.

A16 When defining risks in relation to hazards all initiating events **should** be considered and listed. This will help avoid mistakes when calculating the risk rating and assist in identifying potential mitigations.

A17 The CAA recommends recording all hazards identified during the Risk Assessment process including any hazards identified but deemed not applicable. This information **may** be requested by the [CAA GA Unit](#) during the approval process of a Flying Display or Special Event Permission or by other agencies if required.

A18 Examples of hazards at Flying Displays that **should** be considered as part of the hazard identification process include:

- a) Hazardous materials carried by aircraft
- b) Congested Areas in the vicinity of a Display Area
- c) Electricity pylons
- d) Displaying and non-displaying aircraft
- e) Human Factor influences
- f) Sources of visual confusion
- g) Major and minor roads

- h) Public footpaths and rights of way
- i) Potential areas of congregation of secondary spectators
- j) Occupied properties
- k) Display location topography

A19 Further information on hazard identification can be found in the CAA's [CAP 760](#), 'Guidance on the Conduct of Hazard Identification, Risk Assessment and the Production of Safety Cases'.

Risk Assessment

A20 A risk assessment process starts with defining the risk(s) associated with the hazard(s) previously identified. There **may** be more than one risk associated with a particular hazard and a Risk Assessment **may** need to be conducted for each risk.

A21 The next step is to assess the risks in terms of likelihood and severity. Note that the initial Risk Assessment **should** assume that all legal requirements and good practice guidelines contained within CAP 403 are already being met.

A22 Once the risks have been assessed in terms of likelihood and severity, mitigating actions necessary to reduce the risk to ALARP can be decided upon. Implemented mitigation measures **should** reduce the likelihood of the risk occurring and / or reduce the severity of the outcome if it does.

Risk Likelihood (L)

A23 In order to assess an initial risk likelihood (L) any mitigation measures currently in place to reduce the likelihood **should** be taken into account.

A24 To help assess the likelihood the following questions **should** be asked:

- a) Is there a history of similar occurrences (either at the proposed display location or at others) to the one under consideration, or would this be an isolated occurrence?

- b) What impact do the types of aircraft and display items have on the likelihood of incidents occurring?
- c) How many people are involved and how likely is it that they would be harmed?

A25 A guide to assessing likelihood is in the table below:

Likelihood of Occurrence (L)	
Description	Meaning
Frequent (5)	Likely to occur many times (has occurred frequently)
Occasional (4)	Likely to occur sometimes (has occurred infrequently)
Remote (3)	Unlikely to occur but possible (has occurred rarely)
Improbable (2)	Very unlikely to occur (not known to have occurred)
Extremely Improbable (1)	Almost inconceivable that the event will occur.

Risk Severity (S)

A26 In order to assess the initial severity (S) any mitigation measures that are already in place to reduce the severity **should** be taken into account.

A27 To help assess the severity the following questions **should** be asked:

- a) What harm would be caused?
- b) Would lives be lost?
- c) Who would be affected (pilots, Spectators, bystanders, volunteers, workers, etc)?
- d) What are the likely commercial implications or media interest?
- e) Would there be a loss of reputation?

A28 A guide to assessing severity is in the table below:

Severity of consequences (S)	
Classification	Meaning
Catastrophic (5)	Multiple deaths, usually with loss of aircraft.
Hazardous (4)	Large reduction in safety margins leading to serious or fatal injury to small number of people. i.e. ground fatality and / or pilot fatality.
Major (3)	Significant reduction in safety margins leading to serious incident or injury.
Minor (2)	Minor injury.
Negligible (1)	Any event which is considered to be less severe than 'Minor'

Risk tolerability

A29 Once the likelihood (L) and severity (S) have been defined, a risk tolerability matrix such as the one below can be used to assess how tolerable the risk is.

Risk likelihood (L)	Risk severity (S)				
	Catastrophic (5)	Hazardous (4)	Major (3)	Minor (2)	Negligible (1)
Frequent (5)	Unacceptable	Unacceptable	Unacceptable	Review	Acceptable
Occasional (4)	Unacceptable	Unacceptable	Review	Review	Acceptable
Remote (3)	Unacceptable	Review	Review	Acceptable	Acceptable
Improbable (2)	Unacceptable	Review	Review	Acceptable	Acceptable
Extremely improbable (1)	Review	Acceptable	Acceptable	Acceptable	Acceptable

A30 Using a risk tolerability matrix, the risk can then be classified as either acceptable, to be reviewed, or unacceptable. A suitable risk mitigation strategy can then be developed if required to reduce the risk to ALARP.

Risk rating categories

A31 **Unacceptable:** The likelihood and / or severity of the consequence is intolerable. The Flying Display **must not** proceed as planned; the planned display items and their routines may be reviewed at this point to reduce the risk category. If it remains Unacceptable, mitigation measures to reduce the risk must be implemented in order to control the risk to ALARP and to (at least) the Review category. If, after reducing the risk to ALARP it is still Unacceptable the activity **must not** take place as planned.

A32 **Review:** The severity and / or likelihood is of concern and the risk must be further mitigated. If, after mitigating the risk to ALARP, the risk remains in the review category the FDD must consider the benefit of continuing with the flying display versus the residual risk. If the benefit outweighs the risk, then the FDD may consider the risk tolerable and accept it. If the benefit doesn't outweigh the risk, or the FDD doesn't consider the risk tolerable then, by default, it becomes Unacceptable and the activity, as planned, **must not** go ahead.

a) Review decisions should be made in consultation with the EO as the overall risk owner for the event.

b) Review decisions must be appropriately recorded.

A33 **Acceptable:** The consequence is so unlikely, or not severe enough, to be of significant concern and the FDD considers the risk tolerable. However, a risk being Acceptable does not mean it is ALARP; all risks should be reduced to ALARP to minimise the risk to both pilots and the public.

A34 Remember, for all risk categories, mitigating a risk to ALARP does not alone make it Acceptable or tolerable. The FDD, along with other

interested parties such as the EO and pilots, must judge whether an activity is appropriate or not having properly considered, assessed and judged the risks as per the guidance above.

Risk mitigation

- A35 Mitigation measures are actions or changes, such as changes to operating procedures, equipment or infrastructure that reduce either the severity and / or the likelihood.
- A36 The FDD should always seek to reduce risks to ALARP, regardless of whether they are assessed as Acceptable or Review. By doing so, they will ensure that all risks to both pilots and the public are ALARP.
- A37 As with hazard identification, defining appropriate mitigations will benefit from a formal approach and similar methods **should** be used.
- A38 Generally, risk mitigation strategies fall into three categories:
- a) **Avoidance.** The operation or activity is cancelled or avoided because the safety risk exceeds the benefits of continuing the activity, thereby eliminating the risk entirely
 - b) **Reduction.** The frequency of the operation or activity is reduced, or action is taken to reduce the magnitude of the consequences of the risk
 - c) **Segregation.** Action is taken to isolate the effects of the consequences of the risk or build in redundancy to protect against them

For example, a Flying Display is scheduled to take place by the coast. In the past, boats have gathered to watch the display off shore. This creates the risk that if an accident occurs the public might come to harm.

Actions to mitigate the risk could then include:

- a) **Avoidance.** Cancel the Flying Display which will eliminate both the severity and likelihood. This option will generally only be necessary as a last resort

- b) **Reduction.** Only including light aircraft in the display so that if accidents occur the severity of impact is limited
- c) **Segregation.** Move the Display Area to keep displaying aircraft at a safe distance from where boats congregate

A39 As initial risk ratings **must** assume that the legal requirements and good practice recommendations contained both in CAP 403 and other applicable regulations are in place, further mitigations **must** extend beyond those published.

A40 Mitigating risks to third parties not involved in the Flying Display itself can pose particular challenges for FDDs as it can be difficult to control / predict their location. When seeking to mitigate these risks organisers **should** be aware of the range of options open to them which include:

- a) Engagement with Local Authority Safety Advisory Groups, Highways England, local Highways Authorities and rail network operators where appropriate
- b) Application for road closures and / or Temporary Traffic Orders for the duration of the Flying Display
- c) Providing alternative routes for members of the general public who wish to avoid passing directly by the Flying Display location
- d) Ensuring that there is adequate information provided to the general public, both in advance of and during the display
- e) Engaging with the owners or controllers of land near a display site where the general public might or are known to gather
- f) Providing the Maritime and Coastguard Agency with event details if the display is taking place over water. This will allow appropriate forward planning by Coastguards, both in Operations Centres where they can warn and inform Maritime users by adding information to Maritime Safety Information broadcasts, and Coastguard Rescue Service volunteers who can plan and, if required, re-locate so as to be able to respond to any incident along the shoreline
- g) Contacting harbour authorities to discuss risk mitigation measures that might be possible for displays over a harbour

- h) Informing the public that the safest viewing point is always within designated Spectator areas provided by the EO
- i) Preventing overflight of areas where people have been known to congregate if they cannot be prevented from doing so

Risk Recording

- A41 The CAA recommends that the process used to identify mitigations **should** be recorded along with the mitigations to be implemented. Any mitigations that have been considered, but discounted due to excessive time, money or resource, **should** also be recorded.
- A42 The risk recording process includes a reassessment of the risk rating if the planned mitigations are put in place. The reasons why the mitigating actions affect the final severity and likelihood scores **should** be recorded.
- A43 This record provides proof that the assessment was carried out and can be used as the basis for a later review.

Monitoring and improvement

- A44 Risk assessments should be reviewed regularly to ensure that there have been no significant changes and the hazards and risks have not changed. Consideration should be given to investigating whether improvements can still be made or whether further control measures have become available, there may be lessons learnt from incidents or near misses for example. Risk assessments should be kept up-to-date and details of reviews recorded.

Flying Display Risk Assessment

- A45 The importance of ensuring appropriately qualified and competent personnel are involved in the production of a Flying Display Risk Assessment cannot be over emphasized.
- A46 The Flying Display Risk Assessment is a working document and **should** be reviewed regularly, by suitably qualified and competent personnel, especially during any Safety and Flying Control Committee meetings.

- A47 The Flying Display Risk Assessment **should** be available to all people involved in its effective management. Personnel **should** be accustomed with any part pertinent to their role.
- A48 The hazards identified, risk assessments and subsequent follow-up actions **should** be clearly documented in a Flying Display Risk Assessment which **must** be submitted to the CAA as part of a Flying Display or Special Event Permission application. In order to ensure that all the people associated with an event can understand the content of the Flying Display Risk Assessment, acronyms **should** be avoided, or a glossary provided alongside the register.
- A49 The Flying Display Risk Assessment **should** include each identified hazard, the associated risk(s) and the results of the initial risk assessment which assumes current legal and best practise mitigation measures are in place. Further additional risk mitigation measures (if required) **should** then be recorded along with a re-assessment of the risk rating following implementation.
- A50 Where any participant (such as RAFAT) has produced their own, separate risk assessment for a specific display, the FDD is responsible for incorporating any relevant mitigation measures or requirements found in the participants RA into the main Flying Display Risk Assessment.
- A51 The Flying Display Risk Assessment **should** be reviewed after the event, by suitably experienced and competent personnel, to determine what was managed well and to identify areas where improvements could be made. Findings **should** be recorded in such a way that they are accessible for future events.
- A52 The Flying Display Risk Assessment **must** be made available, on request, to all participants. They will be conducting the activity and therefore need to understand the specific risks associated with an event and the measures that have been undertaken to reduce those risks.

Flying Display Risk Assessment in Flying Display applications

A53 Applicants for Flying Display Permissions are required by the CAA to provide a Flying Display Risk Assessment containing, as a minimum, all of the following information:

- a) **The name of the Flying Display.**
- b) **The Flying Display date(s).**
- c) **Details of the risk assessment team** (i.e. names).
- d) **The date that the risk assessment was conducted / amended / updated.**
- e) **Hazard identification.** Including all of the likely hazards in the Risk Assessment gives the CAA assurance that the hazard identification process is robust.
- f) **Clearly defined risks.** Good risk definitions provide detail about who could be affected by them and will make the Risk Assessment process much easier.
- g) **Pre-mitigation likelihood, severity and risk ratings.** A key point is that these initial ratings **must** assume that regulatory requirements are being met and that the impact of the requirements on controlling the underlying risk has already been addressed.
- h) **Mitigating actions.** Any risk mitigation **should** consider how effectively it will mitigate the risk. Is it a practical and realistic action? Will it be acceptable and followed by the people concerned?
- i) **Post-mitigation likelihood, severity and risk ratings.** It might be helpful to add remarks about how the additional mitigations will reduce the risk. In assessing Risk Assessments, the CAA are looking for evidence that the impacts of the mitigations are being reasonably assessed, and explanation helps with that.
- j) **Comments about any out of the ordinary aspects of the Risk Assessment.** The CAA is looking for assurance that Risk Assessments submitted as part of Flying Display and Special Event applications demonstrate that the risks at the event will be managed effectively. Explanations of any out-of-the-ordinary aspects of the Risk Assessment such as obvious

hazards that are not listed, risk treatments that do not follow the standard approach or anomalous risk ratings help the CAA gain the necessary assurance without having to return to the applicant for further information.

- k) **Review decisions and acceptance of tolerable risks by the FDD and, where applicable, the EO (if a different person).** Where risks have been categorised as Review, the Risk Assessment must record any additional mitigations or details of the decision to accept the risk as tolerable.
- l) **Sign off by the FDD (in all cases) and, where applicable, the EO (if a different person).** A declaration that the risk management activities conducted are suitable and sufficient to manage the risks associated with the Flying Display.

A54 When conducting the hazard identification process, all Flying Display Risk Assessments **must** consider the following hazards **as a minimum**:

- a) Propulsion Failure (e.g. engines, rotor blades, propellers, turbine blades)
- b) Aircraft Collision (e.g. between display or non-display aircraft, birds, UAS, etc.)
- c) Pilot Human Factors
- d) Latent aircraft hazards (e.g. Pyrotechnics, Ejection Seats, Hydraulic fluid, etc.)
- e) Display area topography (e.g. congested areas, tall hazards, occupied properties, etc.)

A55 Consideration **must** also be given in every Risk Assessment to the potential outcome of the hazards identified on any Spectators and Secondary Spectators.

A56 This information allows the CAA to assess whether or not the planned Flying Display follows CAA guidance and that risk management plans reflect the hazards that are present. Evidence is required to demonstrate:

- a) That any risks related to a particular Flying Display location are specifically covered
- b) That all reasonably foreseeable hazards and associated risks have been identified

- c) That the risk scoring process is robust and consistent
- d) That risk mitigations are appropriate.

If the risks to the public caused by the Flying Display cannot be managed to a sufficiently low level, the size of the Display Area **may** need to be revised, the type of display reviewed, or, in extremis, the display cancelled.

- A57 The CAA Flying Display Risk Assessment template [SRG 1303T](#) **may** be used for the submission of Risk Assessment information to the [CAA GA Unit](#) but other formats are acceptable.
- A58 When producing a Flying Display Risk Assessment, it is best practice to consider all hazards from first principles. Previous submissions may be used; however, these **should** only be submitted after a thorough review. Risk Assessments that appear to be a simple 'cut and paste' of a previous submission are not acceptable and will be returned.
- A59 In all cases, risk assessments must provide sufficient level of detail for the CAA to evaluate the robustness of the risk assessment process and to make an assessment of whether or not the Flying Display may proceed.
- A60 An example of the CAA's Flying Display Risk Assessment Template with examples is included below.



SRG 1303T: Flying Display Risk Assessment Template

Guidance on Flying Display Risk Management can be found at Appendix A of CAP 403: www.caa.co.uk/CAP403.

Hazard description = Any condition, event, or circumstance which could induce an accident.
Risk description = The potential consequence and location that could result from the hazard.
L = Likelihood of the Risk occurring; S = Severity of the Risk consequence; Risk Decision = A combination of the likelihood of a risk occurring in conjunction with the severity of the risk that could result; e.g. Unacceptable , Review or Acceptable as referenced in the chart below.
Mitigation measures - Risk control measures additional to CAP 403 requirements to lower the risk to as low as reasonably practical (ALARP).
Remarks - Any other information relevant to the flying display risk management process which has not been captured elsewhere. E.g. clarity or explanation to a risk assessment calculation or mitigation measure.

Risk Tolerability Matrix

Risk likelihood (L)	Risk severity (S)				
	Catastrophic (5)	Hazardous (4)	Major (3)	Minor (2)	Negligible (1)
Frequent (5)	Unacceptable	Unacceptable	Unacceptable	Review	Acceptable
Occasional (4)	Unacceptable	Unacceptable	Review	Review	Acceptable
Remote (3)	Unacceptable	Review	Review	Acceptable	Acceptable
Improbable (2)	Unacceptable	Review	Review	Acceptable	Acceptable
Extremely improbable (1)	Review	Acceptable	Acceptable	Acceptable	Acceptable

SRG 1303T: Flying Display Risk Assessment Template

Flying Display Name:	Flying Display Date:
Names and qualifications of Risk Assessment Team:	Date Conducted:

Example

Hazard Description	Risk Description (including location where appropriate)	Initial rating			Mitigation Measures (if applicable)	Final rating			Remarks (if applicable)
		L	S	Risk Decision U = Unacceptable R = Review A = Acceptable		L	S	Risk Decision U = Unacceptable R = Review A = Acceptable	
<i>Mid-air collision – display & non-display aircraft.</i>	<i>Danger to pilots & persons on the ground both inside and outside the display area.</i>	3	5	U	<i>Warning signage added to areas inside and outside display area. Marshall's to be positioned at all identified access points and bystanders notified of the dangers of viewing the display from non-designated zones.</i>	1	5	R	<i>If a gathering of secondary spectators is identified and refuse to move despite the request of designated Marshall's, then the display will be stopped.</i>
<i>Pilot disorientation</i>	<i>Disorientated pilot losing control inside or outside display area.</i>	3	5	U	<i>Pilots must provide the FDD with a copy of their intended display program at least 3 days prior to the proposed display date (in order to exceed the stipulated CAP 403 minima). Radio transmissions are minimized during displays to avoid distraction.</i>	1	5	R	<i>FDD to brief pilots on disorientation possibility if there is a reduced visibility/horizon.</i>

SRG 1303T: Flying Display Risk Assessment Template

<p><i>UAV/Drones being used by unauthorized persons</i></p>	<p><i>Potential for collision with display aircraft and/or member of the public.</i></p>	<p>3</p>	<p>4</p>	<p>R</p>	<p><i>All security staff to watch for any members of the public bringing a UAV/Drone into the site. Anyone seen doing so is to be denied access to the site. Should a UAV/ Drone be seen flying at the site, or close by the perimeter, all efforts are to be made to find the operator and get the UAV safely onto the ground. The flying display is to be stopped until the UAV/Drone is recovered.</i></p>	<p>1</p>	<p>3</p>	<p>A</p>	<p><i>EO responsible for checking and briefing stall holders and adding signage to ensure no on-site sales.</i></p>
---	--	----------	----------	-----------------	---	----------	----------	-----------------	---

Add additional rows as required

I confirm that this Risk Assessment is suitable and sufficient to manage the risks associated with the flying display as referenced above.

<p>FDD Sign Off</p>	<p>Name:</p>	<p>Signature:</p>	<p>Date:</p>
----------------------------	---------------------	--------------------------	---------------------

<p>Event Organiser countersignature (where applicable) *</p>	<p>Name:</p>	<p>Signature:</p>	<p>Date:</p>
---	---------------------	--------------------------	---------------------

**Not required for single item Airborne FDD displays.*

Appendix B

Written, verbal and telephone briefings

The display pilot's written brief

- B1 The FDD is responsible for ensuring that, in advance of the Flying Display, all participants are sent a written briefing. It is important to distribute this information as early as possible to allow pilots to plan and is particularly important for fast jets which might be a little less flexible in their timings. The quality of the mapping / imagery provided is also vital to aid pilots in planning their displays.
- B2 The content of the briefing will vary depending on the complexity of the Flying Display, but the following items **should**, where appropriate, be included:
- a) Place, date, time (UTC or local time) and duration of the Flying Display
 - b) Name and contact details for the FDD and other key personnel, including those for use on the day of the display
 - c) A copy of any related CAA Permissions and Exemptions issued
 - d) Flying programme
 - e) Map of the display location showing the site layout, Display Area, local area and local hazards / avoids. In addition, the use of clearly marked satellite images and / or overhead photographs (if available) often provide a very powerful, clear pictorial image for pilots to familiarise with during display preparation and planning. If using such images, for standardisation, the following colours are suggested:

Suggested colour coding of lines on maps ⁵²	
Orange	150 metre display line
Red	230 metre display line
Blue	450 metre display line
Yellow	Restricted areas (no overflight / no aeros / min heights for example)
Red triangle	Display datum
Green	Spectator areas, Car Parks and Crowd Line.



⁵² In addition to the example display lines shown above, further benefit may be gained from the illustration of Display Area boundaries (not shown) on satellite images.

- f) Flying Display minima
- g) Details of how Display Lines will be marked at the site and how they will be recognised on the day by the pilot
- h) Details of the display datum, whether an easily identifiable feature, a Lat / Long or a grid reference
- i) Air Traffic Services information including:
 - i) Type of air traffic service available to pilots – A/G, AFIS or ATC
 - ii) Arrival and departure procedures (including taxi instructions)
 - iii) Radio frequencies and, if required, transponder codes
 - iv) Procedures during the Flying Display
 - v) Radio failure procedures
 - vi) Holding areas and altitudes
 - vii) Adjacent air traffic conflicts
 - viii) Local flying restrictions
 - ix) Local diversion airfields
- i) Details of any NOTAM or RA(T) which might have been established for the event, including lateral and vertical extent and times of activation
- j) Any deviations from Flying Display limits and weather minima set out in CAP 403
- k) Procedures to be followed when the Flying Display includes items such as ballooning, parachuting, parascending, paragliding, hang-gliding, banner towing and foot launched aircraft
- l) Procedures for cancellation or variation of the flying programme
- m) Details of aircraft parking and refuelling arrangements
- n) Arrangements for any Pleasure Flights and visiting aircraft
- o) References to Emergency Service cover and any specific procedures
- p) Details of place and time where the formal pre–display verbal briefing will be conducted at the event
- q) Details of arrangements for telephone briefings for any pilot unable to attend the formal pre-display briefing

- B3 It is recommended that where possible the display pilot's written brief is produced in a bound A5 format. In addition, it is recommended that one of the cover pages consists of a crib sheet with an acetate overlay to facilitate pilot's noting significant information as suggested in the following illustration:

Flying Display name, location and date.	
Area for listing prominent details such as ATS frequencies, FDD contact details, location and time of briefing, etc.	
Airfield Pressure Setting	
Airfield Surface Wind	
Preceding Display Item	
T/O time	
Display Time ON	
Display Time OFF	
Following Display Item	
Space for inclusion of any other significant information, instructions, maps, notes, etc	

The verbal brief

- B4 The FDD is responsible for ensuring that all participating pilots receive a thorough verbal briefing before the Flying Display on each day of the event. A copy of the Flying Display Permission **must** be available at the briefing.
- B5 Flying Display Briefing Checklist (and Telephone Brief if required).

Flying Display briefing checklist	Notes
Attendance check / Roll call.	
Time check (specify UTC or Local time).	
Show a large-scale map of the Display Area , showing display lines, display area, avoid areas, car parks, <u>spectator</u> areas or any other sensitive areas.	
Show a copy of the CAA Flying Display Permission , to include any conditions attached to it.	
Air Traffic operations briefing:	Notes
Type of service available (A/G, FIS or Full ATC)	
Arrival & departure procedures	
Radio frequencies, transponder codes	
Display procedures	
Holding areas & altitudes	
Adjacent air traffic conditions	
Local flying restrictions	
Full details of diversions airfields	
Ejection & abandonment areas	

Weather briefing:	Notes
Current conditions	
Forecast conditions	
Weather forecast for diversion airfields	
Any local weather conditions / effects	
Weather minima for the display	
Ground briefing / arrangements:	Notes
Arrival & departure procedures	
Parking areas	
Refuelling arrangements	
Flying programme:	Notes
Confirmation of pilots, aircraft, call signs	
Flying Display minima	
Display programme timing ⁵³	
Alternative plans if incidents or weather holds	
If parachute activity, stress the need for no rotors / engines turning	
Any other activity? (before, arrivals, departures after display)	
Handling of ground & air emergencies	
Contact numbers & locations for:	Notes
Flying Display Director	
ATS provider	
Event Organiser	
Any other relevant contacts	
Questions?	

⁵³ To include details of previous and subsequent display items

Telephone briefing

B6 At Flying Displays at non-airfield sites, or for Participants who are flying into a display from a different location, a briefing **may** be conducted by telephone.

The briefing conducted by the FDD **should** be from an identical crib sheet (written specifically for the telephone briefing) to the one issued to the pilot as part of the briefing material, containing all the relevant safety items for that pilot.

Formation briefings and walk throughs

B7 A formation leader is responsible in ensuring that a thorough formation briefing is given and must ensure sufficient time is available to conduct one.

B8 All formations at Flying Displays **must** be briefed prior to flying⁵⁴; the brief **should** include a walk through. The following **must** be briefed as a **minimum**:

- a) Overview - Leader establishes the skill level and recent formation experience of formation members, gives an overview of the intended display, and confirms that members have the required competence
- b) The formation positions of each pilot and aircraft
- c) SUTTO – start-up procedures, taxi order and spacing, line-up positioning, takeoff formation and stream interval as appropriate
- d) Formation join-up
- e) Formation changes
- f) Formation spacing
- g) Formation flypast / aerobatic minimum height(s) (the most restrictive of the entire formation)⁵⁵

⁵⁴ Where possible, formation leaders should circulate pertinent pilots notes prior to their formation briefing.

⁵⁵ For formations (including display teams) consisting of pilots who hold differing DA minima, leaders must adopt the highest individual minima for the whole formation whilst flying in formation. Recognising that formation members may be stepped down the leader must fly at a height which permits the lowest aircraft to remain above the required minimum height.

- h) Formation minimum separation distance from the crowd (the most restrictive of the entire formation and how the leader will ensure that formation members do not infringe the applicable minima)
- i) Display components such as aerobatic elements, splitting into sub formations, separation, tailchase elements (aerobatic and non-aerobatic), timings, and situational awareness calls.
- j) Recovery / landing sequence
- k) Loser plan (including formation leadership)
- l) Break-out, unsighted, loss of situational awareness (SA)
- m) Emergencies – power loss, systems failures, shepherding, radio failure
- n) Questions – Leader to confirm that members have understood the brief and are prepared to proceed. If the formation leader is not content with the ability, currency or competence of any of the pilots in the formation, then the leader should not allow that pilot to take part in the formation

B9 Following the formation detail, the formation leader **should** conduct a post flight debrief to identify any safety issues and lessons learnt.

Appendix C

Flying Display Director Accreditation

Obtaining Flying Display Director accreditation⁵⁶

- C1 To gain accreditation as an FDD, applicants are required to complete the following:
- a) For applicants with prior FDD experience, advice on application and any mentoring requirements are to be sought from the [CAA GA Unit](#) or the [MAA](#) as appropriate⁵⁷.
 - b) For initial FDDs with no prior FDD experience⁵⁸, gain agreement to be mentored from an existing [accredited FDD](#) mentor (FDDM).
 - c) Gain the requisite experience (as outlined in the Flying Display Director Accreditation section below) through shadowing the FDDM⁵⁹.
 - d) Perform the functions associated with applying for and running a Flying Display under the supervision of the FDDM⁶⁰.
 - e) Apply for FDD accreditation via form [SRG 1326](#). Completed forms **should** be submitted to [CAA GA Unit](#) as an email attachment with the subject line 'FDD accreditation application'. The application **must** be supported by a comprehensive training record from the FDDM. This training record can take many forms such as a training

⁵⁶ If an organisation or individual wishes to suggest an alternative method of accreditation they can contact the FDD Co-ordination Officer at ga@caa.co.uk.

⁵⁷ Flying Displays directed overseas are acceptable experience where the host country's regulation is based on CAP 403.

⁵⁸ Valuable and valid experience can be gained as a member of an FCC. FCC members aspiring to become FDDs **should** log any experience gained. This **should** be counter-signed by the relevant event FDD.

⁵⁹ Courses are available for training in many aspects associated with the role of the FDD such as public safety planning, risk management, crowd management, incident planning, etc. Applicants might find these beneficial and will add credibility to any application made for FDD [accreditation](#).

⁶⁰ Candidates must ensure that any experience gained is accurately logged and certified by the FDDM.

folder or log, but **must** be detailed enough to allow the CAA to review the applicant's progress and performance.

- f) Undergo a behavioural and attitudinal fitness assessment. A completed form [SRG 1303B](#) **must** be submitted at the time of application for FDD accreditation to allow sufficient time for processing prior to commencing the FDD accreditation process⁶¹.
- g) Attend a joint CAA / MAA FDD Accreditation course. Details of course dates can be found on the [CAA website, on the www.fddtraining.co.uk website](#) or by contacting the [CAA GA Unit](#).
- h) Arrange for a CAA Flight Standards Officer to attend a Flying Display at which the applicant is acting as FDD under supervision

Flying Display Director accreditation course

C2 The CAA and MAA will provide a joint FDD Accreditation Course in order to accredit FDDs in the UK. Any person intending to act in the role of FDD is required to pass the FDD Accreditation Course.

C3 The course covers a number of topics specific to display flying as well as the planning, organisation and management of Flying Displays, in addition to presentations from the regulators and experienced members of the display community. An Applicant's performance is observed during group workshops and assessed via a written examination in a number of areas:

- a) Regulatory compliance
- b) Planning and organising safe Flying Displays
- c) Flying Display Risk Assessment management and review
- d) Obtaining necessary Permissions and planning display in accordance with regulatory rules
- e) Air Traffic Service provision and radio communication at displays
- f) Maintaining flying discipline
- g) Briefing and debriefing of participating aircrew

⁶¹ If an applicant has concerns as to whether or not a favourable behavioural and attitudinal fitness assessment outcome is achievable, it is recommended that a form [SRG 1303B](#) be submitted for assessment to [CAA GA Unit](#) before commencing any of the requirements outlined above.

- h) Safe coordination of Flying Displays and Flying Display programmes
- i) Cancellation or modification to the programme in the case of adverse weather or other conditions
- j) Flying Display monitoring and warning calls
- k) FCC & FDD coordination
- l) Dealing with contingencies
- m) Post display briefing
- n) MOR and post event reporting
- o) Learning from what happens
- p) Understanding of human factor influences on the safety of Flying Displays and how to address them
- q) Knowledge of AAIB and display accident investigation

C4 A joint CAA / MAA panel will be convened after FDD Accreditation Courses to review applicants' performance during the course. This panel will consider the experience, qualifications, interaction during the course and results of examinations before accrediting to either Tier 1, 2 or 3⁶².

C5 **'Civ' and 'Mil' Accreditation.** The panel will also consider, based on the experience of the individual and the knowledge displayed during the FDD accreditation course, whether they will be accredited as a 'Civ', 'Mil' or 'Civ / Mil' FDD.

- a) **Civ.** The individual is only permitted to be FDD / DFDD at Flying Displays regulated by the CAA under CAP 403.
- b) **Mil.** The individual is only permitted to be FDD / DFDD at Flying Displays regulated by the MAA under RA2335.
- c) **Civ / Mil.** The individual is permitted to be FDD / DFDD at either CAA or MAA regulated Flying Displays⁶³.

⁶² Initial FDD applicants will only normally be issued with a maximum tier 1 accreditation. However, previous experience will be taken into account and such applicants **may** be accredited at a higher tier level.

⁶³ Depending on the considerations made in C5, When awarding a Civ / Mil accreditation, the panel may assign separate Tier levels when appropriate, for example 'Civ 2 / Mil 1'

Validity and currency

- C6 Validity. FDD accreditation will remain valid for a period of 3 years subject to ongoing fitness for the role⁶⁴. Behavioural and attitudinal fitness assessments are valid for 1 year. A completed SRG 1303B is to be submitted each year prior to, or alongside, the first Flying Display application made by the individual FDD.
- C7 Currency. To maintain currency an individual **must** act as FDD within the appropriate tier at least once every two years⁶⁵. However, if, for example, a tier 3 FDD has only acted as FDD for a tier 1 or 2 Flying Display(s) within the currency period, the tier 3 privileges will be forfeited at the end of the currency period.
- C8 Currency can be maintained by acting in the role of DFDD provided the following requirements are met:
- The individual **must** be nominated on the CAA [application](#) for a Flying Display Permission, or on the [RA 2335 Form 1](#) for MAA regulated events.
 - The individual **must** take an active part in the planning and execution of the Flying Display.
 - The individual **must** be in attendance for the duration of the Flying Display.
 - The primary FDD **must** ensure that the nature of the active role and precise level of participation of the DFDD is recorded in the Post-Display Feedback Form ([SRG1305 / Form 4](#)). The primary FDD **must** record as part of the detail included on the form that the DFDD intends to use the event to reset their currency status⁶⁶.

Currency requirements relating to tier levels apply as detailed in the previous paragraph.

⁶⁴ Successful completion of a FDD accreditation course is required every 3 years to maintain [validity](#).

⁶⁵ AFDD duties do not count towards currency requirements for ground based FDDs

⁶⁶ The responsibility for recording this information on the form rests with the primary FDD in conjunction with the DFDD and not the CAA / MAA.

- C9 Successful completion of a FDD Accreditation Course will automatically reset both the status of the 3-year FDD accreditation validity and the 2-year currency at the Tier for which they are accredited.

Upgrades

- C10 Upgrading to a higher tier of FDD accreditation can be achieved by progressing through each complexity level in turn. For clarification, a tier 1 FDD can only upgrade to a tier 2 and a tier 2 to a tier 3. Once an FDD has achieved a higher level of accreditation, a period of consolidation⁶⁷ is required before any further upgrade can be considered.

To upgrade to a higher FDD tier level, applicants are required to complete the following:

- a) Gain agreement to be mentored from an existing accredited FDD Mentor⁶⁸.
- b) Be able to demonstrate experience at the higher level of complexity including, but not limited to, the following areas⁶⁹:
 - i) Planning a safe Flying Display (including the risk assessment)
 - ii) Obtaining the necessary Permissions
 - iii) Understanding and compliance of Flying Display regulations
 - iv) Management and assessment of participant regulatory compliance
 - v) The briefing of participating aircrew
 - vi) Control of the Flying Display programme (including active management and monitoring)
 - vii) Simulated emergencies
 - viii) Post display debriefing

⁶⁷ This period needs to be sufficient to allow the applicant to demonstrate the required competencies at the new level prior to being considered for a further upgrade.

⁶⁸ Experience can be gained by acting as FDD under supervision. Nomination as such can be included on a Flying Display Permission with prior agreement from CAA GA Unit. Names of FDDMs can be found on the accredited FDD list.

⁶⁹ For tier 1 FDDs applying to upgrade to tier 2, elements of this experience can be gained by active involvement as a member of the FCC at tier 2 and 3 events under the direction of the FDDM.

- ix) Production of [SRG 1305/Form 4](#) 'Flying Display Director Post Display Feedback Form'
- c) Act as FDD under the supervision of the FDDM at a minimum of 3 Flying Displays at the higher level of tier complexity.
- d) Apply for FDD accreditation via form [SRG 1326](#) outlining the experience gained in the categories above in the area provided. The application **must** be supported by a comprehensive training record from the FDDM. This training record can take many forms such as a training folder or log but **must** be detailed enough to allow the CAA to review the applicants progress and performance.
- e) Undergo a behavioural and attitudinal fitness assessment by submitting a form [SRG 1303B](#)
- f) Arrange for a CAA Flight Standards Officer to attend a Flying Display at which the applicant is acting as FDD under supervision in order for the CAA to accredit the applicant to the higher tier⁷⁰.

Mentoring / shadowing

- C11 A tier 1 or tier 2 accredited FDD can 'shadow' the primary FDD of a higher tier event in order to build experience⁷¹. This 'shadow' role can be used to improve the level of competence or with a view to upgrading to a higher tier in the future.
- C12 The primary FDD **should** record the level of participation of the 'shadow' FDD on the [SRG1305/Form 4](#) to enable the CAA / MAA to properly assess the level of experience of the individual.
- C13 Unless the primary FDD is a 'mentor', they **should not** comment on the ability or performance of the 'shadow' FDD but limit their comments to their participation level (i.e. the level of their involvement in the planning and / or execution of the Flying Display).

⁷⁰ CAA FSO observation can be carried out on the third of the required series of Flying Displays quoted in paragraph c) above.

⁷¹ An un-accredited person may 'shadow' any FDD in order to gain experience for initial FDD accreditation. Additionally, an FDD may wish to shadow an equally qualified FDD to widen their experience (a tier 2 shadowing another tier 2 but at a different type of site for example).

C14 If the Primary FDD is a 'mentor', the 'shadow' FDD **should** ensure that the participation in the planning and / or execution of the Flying Display is appropriately logged and countersigned by the Primary FDD so that any experience gained can be demonstrated at the time of application for upgrade.

Renewals

C15 The renewal of FDD accreditation can be made at any time within the validity period. The requirements for renewal are:

- a) To be able to satisfy the currency requirements detailed above
- b) To have attended a CAA / MAA FDD Accreditation Course

C16 Once the above requirements have been met, candidates can apply for re-accreditation by completing forms [SRG 1326](#) and [SRG 1303B](#) and submitting them, along with supporting evidence, to the [CAA GA Unit](#).

C17 Following receipt of the application form, the candidate's suitability will be assessed with regard to the following criteria:

- a) The content of the supporting information contained with the application (including examination results)
- b) The quality and content of post display feedback reports submitted during the previous period of validity
- c) Observations made during any CAA Flying Display inspections carried out during the previous period of validity

C18 If acceptable, the candidate will then be accredited for a further 3 year validity period.

Lapsed and expired FDDs

C19 FDD accreditation is considered lapsed if the minimum currency requirements stated above have not been met. In this case the FDD will need to re-apply by submitting forms [SRG1326](#) and [SRG 1303B](#) to the

[CAA GA Unit](#). The CAA GA Unit will then advise on the requirements needed for re-validation.

- C20 FDD accreditation is considered expired if the currency requirements have not been met and a period in excess of 3 years has elapsed since last renewal. In this case the FDD will need to re-apply for FDD accreditation as above and attend a FDD Accreditation Course. The [CAA GA Unit](#) should also be consulted as, dependant on the period of time expired, further mentoring and / or experience **may** be required.
- C21 FDDs who are current but have forfeited privileges **may** be re-accredited to their previous tier by shadowing an appropriately accredited FDD at a Flying Display. Once satisfactory evidence has been submitted to the CAA GA Unit, previously held privileges **may** then be restored.

Revocation

- C22 In the event of a FDD who is found to be underperforming an investigation will be undertaken in accordance with the Flowchart Analysis of Investigation Results (FAiR) System detailed at Appendix D⁷².
- C23 Once the investigation is complete, a decision will be made as to whether any further action is required. Actions can include continuing in role, downgrading to a lower FDD tier level, suspension, further training / mentoring or revocation⁷³.
- C24 Appeals **should** be made to the [CAA GA Unit](#) within 14 days of notification⁷⁴.

⁷² [FAiR@3 System , Version 31 , March 2019 , © Baines Simmons Limited](#)

⁷³ In accordance with the Air Navigation Order, Article 253 'Revocation, suspension and variation of certificates, licences and other documents'

⁷⁴ In accordance with Regulation 6 of The Civil Aviation Authority Regulations 1991.

Appendix D

FAiR System

D1 Flowchart Analysis of Investigation Results (FAiR) System⁷⁵. Distinction between Non-Judgmental and Judgemental phases of an investigation.

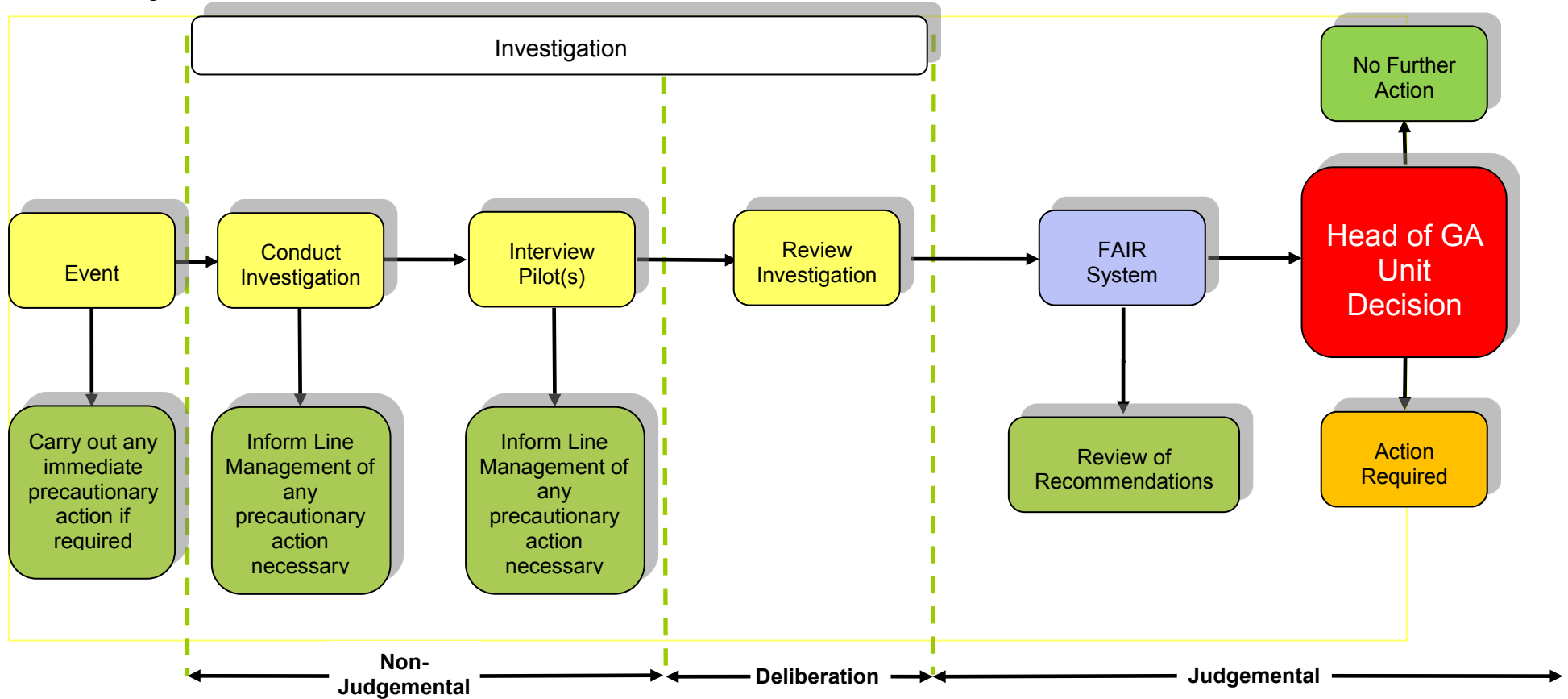

⁷⁵ FAiR@3 System , Version 31 , March 2019 , © Baines Simmons Limited

D2 Just culture, behavioural types.

FAiR[®]3 Behaviour Identification

START: Review the factual, non-judgmental, human performance oriented investigation data provided by your trained investigators

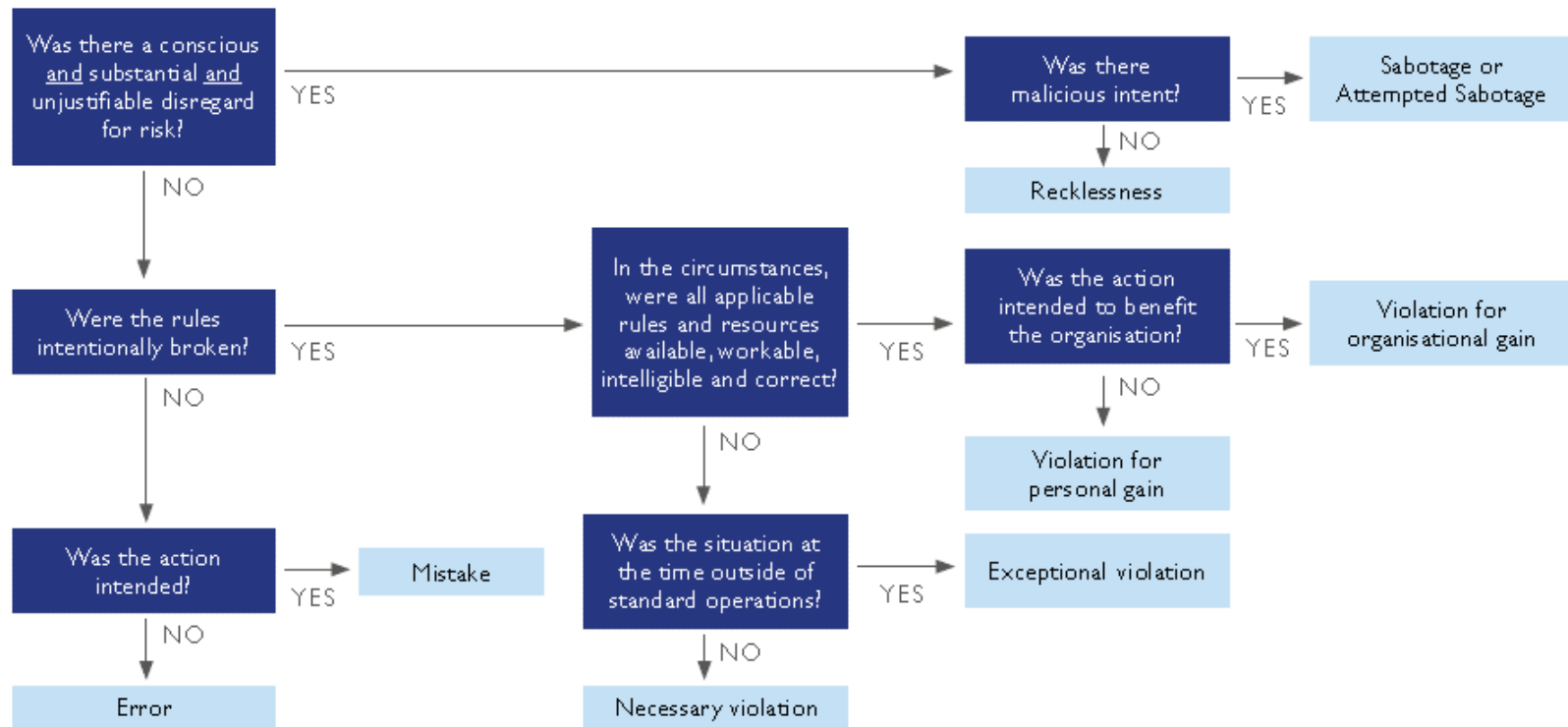

D3 Accountability framework

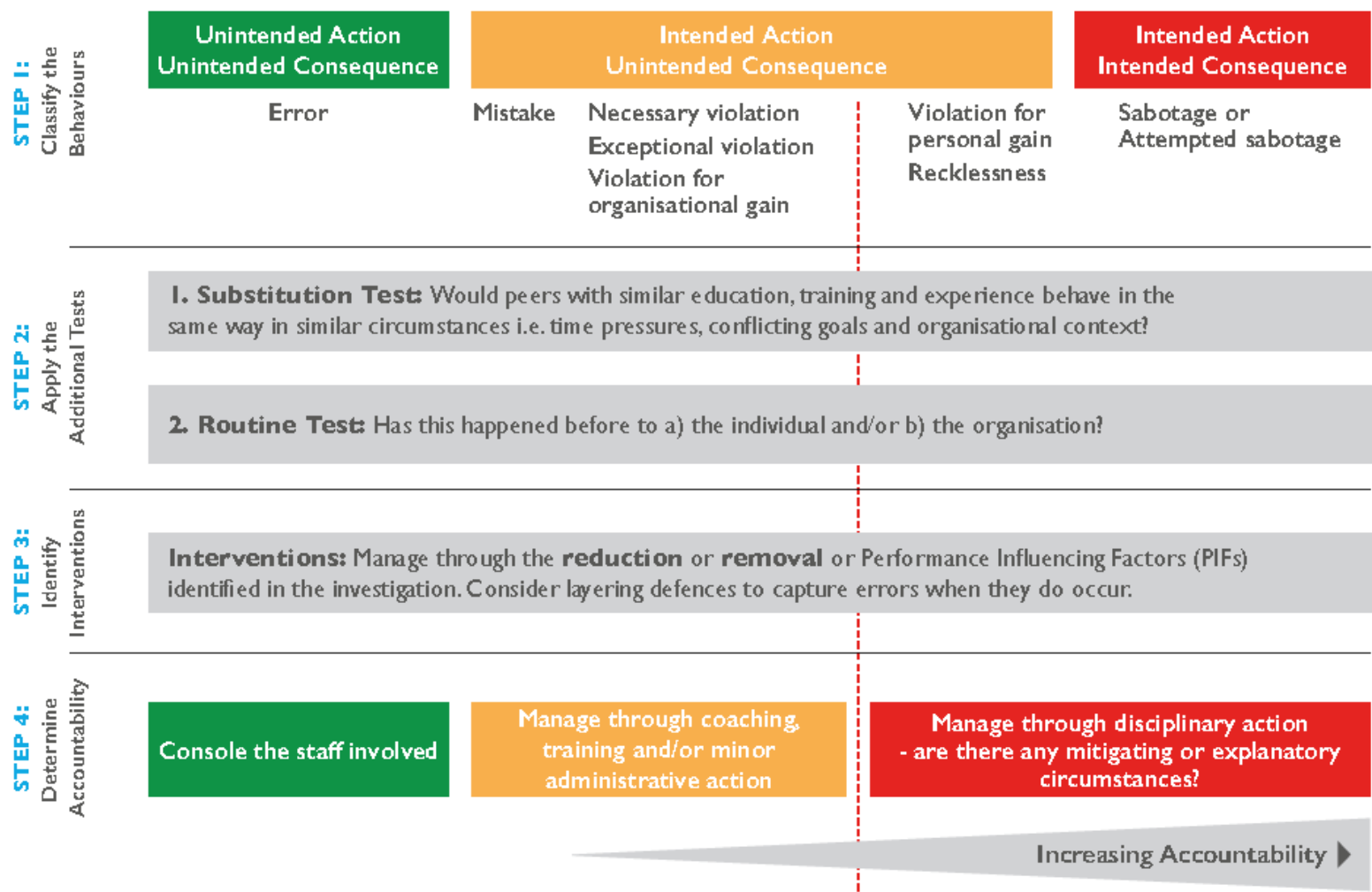

D4 The references and excerpts to FAiR in this chapter have been reproduced with the permission of the copyright holder Baines Simmons Limited. Further information concerning the FAiR System can be found at: <https://www.bainessimmons.com/aviation-consulting-services/smart-tools/fair-system/>